



**bPro<sup>®</sup>**  
**User's Guide**

**METTLER TOLEDO**

©Mettler-Toledo, LLC 2015

No part of this manual may be reproduced or transmitted in any form or by any means, electronic or mechanical, including photocopying and recording, for any purpose without the express written permission of Mettler-Toledo, LLC.

U.S. Government Restricted Rights: This documentation is furnished with Restricted Rights.

---

## Publication Revision History

Part Number	Date	Revisions
64067202 R00	12/08	New manual
64067202 R01	04/10	Revisions to chapters 1, 2, 3, 5 and 6
64067202 R02	06/13	Added FCC Notice Section.
64067202 R03	05/15	Updated Clone Scale section

---

## Trademarks

METTLER TOLEDO® bPro® are registered trademarks of Mettler-Toledo, LLC Columbus, OH, USA.

---

## FCC Notice

This device complies with Part 15 of the FCC Rules and the Radio Interference Requirements of the Canadian Department of Communications. Operation is subject to the following conditions: (1) this device may not cause harmful interference, and (2) this device must accept any interference received, including interference that may cause undesired operation.

This equipment has been tested and found to comply with the limits for a Class A digital device, pursuant to Part 15 of FCC Rules. These limits are designed to provide reasonable protection against harmful interference when the equipment is operated in a commercial environment. This equipment generates, uses, and can radiate radio frequency energy and, if not installed and used in accordance with the instruction manual, may cause harmful interference to radio communications. Operation of this equipment in a residential area is likely to cause harmful interference in which case the user will be required to correct the interference at their own expense.

# Precautions

READ this manual BEFORE operating or servicing this equipment.

FOLLOW these instructions carefully.

SAVE this manual for future reference.



DO NOT allow untrained personnel to operate, clean, inspect, maintain, service, or tamper with this equipment.



ALWAYS DISCONNECT this equipment from the power source before cleaning or performing maintenance.

CALL METTLER TOLEDO® for parts, information, and service.

METTLER TOLEDO® reserves the right to make refinements or changes without notice.

	<b>NOTICE</b>
	<b>TO PREVENT EQUIPMENT DAMAGE</b> Read and understand the operators manual before using the equipment. Failure to follow operating instructions could result in equipment damage.

	 <b>WARNING</b>
	<b>ELECTRICAL SHOCK HAZARD</b> Only permit qualified personnel to service this equipment. Exercise care when making checks, tests and adjustments that must be made with power on.

	 <b>WARNING</b>
	<b>ELECTRICAL SHOCK HAZARD</b> Connect to a properly grounded outlet only. Do not remove the ground prong. Power outlets must be easily accessible and located no further than the length of the power cord supplied with the product.

	 <b>WARNING</b>
	<b>ELECTRICAL SHOCK HAZARD</b> Disconnect and lock out all power to this unit before removing or installing the fuse, cleaning, or servicing.

	<b>NOTICE</b>
	<b>ELECTROSTATIC SENSITIVE DEVICES</b> Observe precautions for handling electrostatic sensitive devices.

	<b>NOTICE</b>
	<b>EQUIPMENT DAMAGE</b> Disconnect power before connecting or disconnecting any internal electronic components or interconnecting wiring between electronic equipment.

# CONTENTS

<b>1</b>	<b>Introduction .....</b>	<b>1-1</b>
	<b>General .....</b>	<b>1-1</b>
	<b>Specifications .....</b>	<b>1-2</b>
	<b>Power Switch .....</b>	<b>1-3</b>
	<b>Network Connection.....</b>	<b>1-3</b>
	<b>Leveling the Scale.....</b>	<b>1-4</b>
<b>2</b>	<b>Operating Instructions .....</b>	<b>2-1</b>
	<b>Machine Configuration.....</b>	<b>2-1</b>
	<b>Keyboard .....</b>	<b>2-2</b>
	<b>Text Editing Mode .....</b>	<b>2-4</b>
	<b>Main Screen .....</b>	<b>2-6</b>
	<b>PLU Pricing Modes .....</b>	<b>2-7</b>
	By-Weight PLU.....	2-7
	By-Count PLU .....	2-7
	Standard Pack PLU.....	2-7
	<b>PLU Screens .....</b>	<b>2-8</b>
	<b>Calling Up PLUs .....</b>	<b>2-9</b>
	<b>Printing Labels.....</b>	<b>2-10</b>
	<b>Temporary Overrides .....</b>	<b>2-11</b>
<b>3</b>	<b>Configuration.....</b>	<b>3-1</b>
	<b>Introduction .....</b>	<b>3-1</b>
	<b>Program Menu .....</b>	<b>3-2</b>
	<b>Database .....</b>	<b>3-3</b>
	<b>Quick PLU Change .....</b>	<b>3-4</b>
	<b>Database PLU .....</b>	<b>3-5</b>
	<b>Database Extra Text .....</b>	<b>3-7</b>
	<b>Database Nutrifacts .....</b>	<b>3-8</b>
	<b>Database Special Message .....</b>	<b>3-9</b>
	<b>Database COOL Text .....</b>	<b>3-9</b>
	<b>Database Traceability .....</b>	<b>3-10</b>
	<b>Database Delete .....</b>	<b>3-11</b>
	<b>Clone Scale .....</b>	<b>3-12</b>
	<b>Print Reports.....</b>	<b>3-12</b>
	<b>Service Mode.....</b>	<b>3-12</b>
	<b>Password Setup .....</b>	<b>3-12</b>
	<b>Unit Setup.....</b>	<b>3-13</b>
	<b>PLU Auto Call .....</b>	<b>3-15</b>
	<b>PLU Display Options .....</b>	<b>3-15</b>
	<b>Active Tare .....</b>	<b>3-16</b>
	<b>PLU Display Align .....</b>	<b>3-16</b>
	<b>PLU Presets .....</b>	<b>3-17</b>
	<b>Default Label Format .....</b>	<b>3-17</b>
	<b>Delete Custom Formats .....</b>	<b>3-18</b>
	<b>Serial Port.....</b>	<b>3-18</b>
	<b>Network Address .....</b>	<b>3-19</b>

	Wireless Configuration .....	3-20
	Store Information .....	3-20
	Store Logo .....	3-21
	Scale Number .....	3-21
	Marquee .....	3-22
	Barcode Settings .....	3-23
	PLU Settings .....	3-23
	Set Time and Date .....	3-24
	Assign Group Names .....	3-24
	Enable Function Keys .....	3-25
	Language .....	3-25
	User Define .....	3-26
	Sales Online .....	3-27
	<b>Process Mode .....</b>	<b>3-28</b>
<b>4</b>	<b>Labels .....</b>	<b>4-1</b>
	Loading Labels .....	4-1
	Default Label Styles .....	4-5
	Label Requirements .....	4-6
	Label Paper .....	4-6
	Label Stripping .....	4-7
	Finished Label Roll Requirements .....	4-7
	Finished Label and Roll Dimensional Requirements .....	4-10
	Preprinted Labels .....	4-12
	Special Shaped Labels .....	4-14
	Definition of Transmission Optical Density .....	4-14
	Label and Liner Optical Density .....	4-15
	Black Stripe Optical Density .....	4-15
<b>5</b>	<b>Maintenance .....</b>	<b>5-1</b>
	Unit Cleaning .....	5-1
	Printer Cleaning .....	5-2
<b>6</b>	<b>Appendix .....</b>	<b>6-1</b>
	Define barcode Digits .....	6-1

# 1

## Introduction

### General

Thank you for purchasing the feature rich bPro<sup>®</sup> scale. METTLER TOLEDO designed the bPro series as a solution for both current and future requirements. The bPro can handle a variety of operations and easily adapts to changing process and data requirements. This flexibility protects your investment and helps you keep pace with rapidly changing production and customer demands.



The METTLER TOLEDO bPro scale offers intuitive functionality with a user friendly interface. All scales contain a built-in thermal label printer designed for easy roll changes and maintenance as well as a reliable, state-of-the-art load cell to ensure years and years of accurate product usage.

## Specifications

Description	Specifications – bPro
Capacity x Division	6 x 0.002 kg / 15 x 0.005 kg 15 x 0.005 lb / 30 x 0.01 lb
Weighing Modes	lb , kg, (single and dual interval)
Dimensions	H: 19.3", W: 15.4", D: 20.9" H: 492mm, W: 390mm, D: 530mm (max)
Platter Dimension	W: 15.75" x D: 9.75"
Weight of Unit	23.0 lb (10.5 kg)
Shipping Weight	24.9 lb (11.3 kg)
Base Construction	Aluminum die cast
Operator Display	Backlit monochrome 240 x 240 LCD
Operator Keyboard	98 key tactile keypad with rubber overlay
Customer Display	Backlit monochrome 240 x 240 LCD
Printer	2.2" (56mm) max width labels at up to 4.5" (115mm)/sec 4.7"/120mm roll capacity
Power	100-240 VAC, 50/60 Hz, 1.0A
Operating Temperature	0° C to 40° C, humidity 5% to 95% non condensing
Storage Temperature	-20° C to 70° C with humidity from 5% to 95% non -condensing
Network Interface	Ethernet Standard 10/100 MBPS RF optional 802.11b/g RF RS-232 Host Communications
Memory	4 Megabytes SDRAM
Optional Extended Memory	8 Megabyte expansion
Available Serial port	One



## Power Switch

The power switch and power cord jack are located under the keypad at the left front of the scale.

Press I to turn the scale on. Before turning the unit off, exit any screen-editing menus.



## Network Connection

The bPro can connect to your Ethernet network using a cable or via the optional wireless radio. If you use a wired network connection and experience connection problems, make sure your Ethernet cable is connected and seated securely in the jack, located under the keypad at the front of the scale.

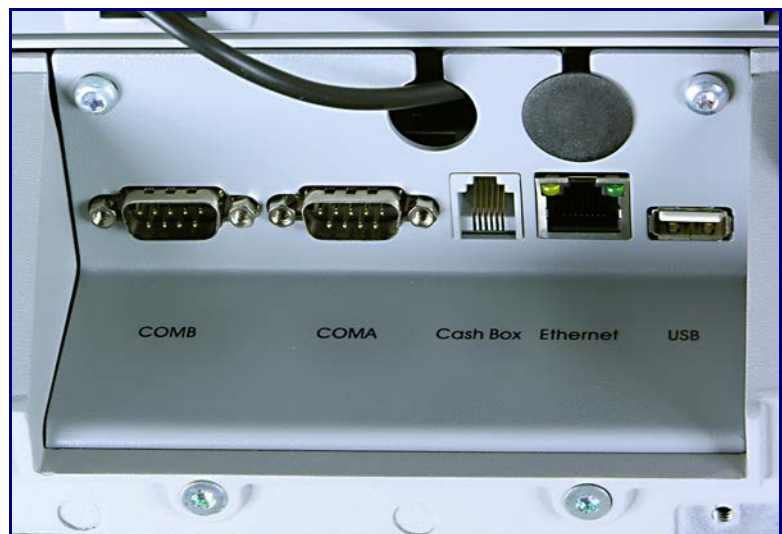

The bPro wireless card connects to the normal Ethernet port via a supplied cable that must be routed through either of the two access holes shown in the above photograph.

## Leveling the Scale

Adjust the four feet until the bubble, located under the scale platter, is in the center of the leveling circles. Adjust the foot-lock jam-nuts until the feet are secure.

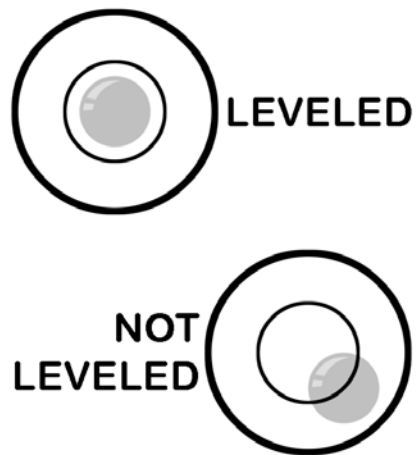

# 2

## Operating Instructions

### Machine Configuration

The customer/operator display of the bPro unit mounts to the tower behind the weigh platter and has a vivid orange over black. The primary user interface is the keypad at the front of the scale; the right side of the keypad hosts the navigation functions whereas the left side is used mostly for typing, preset selection and specific numbering.



## Keyboard

The keyboard consists of a membrane switch-pad and an overlay that provides tactile feedback and an audible tone when the keys are pressed. The 28 keys on the right-hand keypad are used for entering basic scale functions in the various scale modes. Any alternate functionality is listed in smaller text on each key.

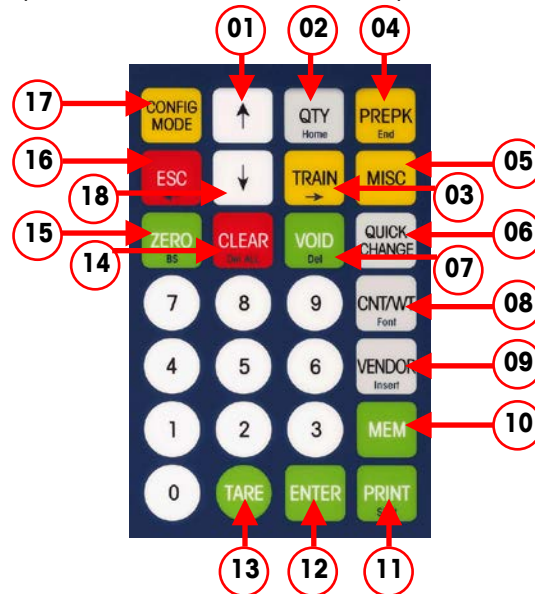

Keyboard Functions

- |    |   |
|----|---|
| 1  | Used to scroll through possible selections including yes/no paths and selects between preset layers 1 and 2   |
| 2  | Enters the quantity of PLU labels to be printed in batch mode   |
| 3  | Training Mode – transactions are not registered in reports when in this mode. In receipt mode, “training” will be printed on the ticket. In label mode a horizontal line will be painted on the label to indicate an invalid label. This function can be password protected |
| 4  | Toggles between Prepack and Service mode. In Prepack mode, a label is printed each time the weight on the platter fluctuates (corresponding to a new package)   |
| 5  | Miscellaneous key allows the user to enter a unit price and print a label for an item that is not in the PLU database. This function can be password protected  |
| 6  | Accesses the menu for temporary overrides of Price, Shelf Life, Date, etc.  |
| 7  | voids a PLU transaction from accumulation totals  |
| 8  | Overrides quantity/count of Standard Pack/By Count PLUs. Overrides the net weight field within a Standard Pack PLU  |
| 9  | Input operator ID   |
| 10 | Input PLU in transactional receipt mode; input functional preset key in programming mode  |
| 11 | Prints a label or feeds a blank label when the weight value is at zero  |
| 12 | Accepts displayed data or displayed selection   |
| 13 | Overrides programmed tare of a called By-Weight PLU. Enter the tare numerically (keyboard tare) or place an item on the platter and press <b>TARE twice</b>   |
| 14 | Clears incorrect entries or messages from the display. Backs out of PLU screens   |
| 15 | Sets weight value to zero   |
| 16 | Backs up in the Menu  |
| 17 | Accesses Setup Mode and Database functions; press CONFIG and PRESET for functionality quick key   |
| 18 | Call PLU by item number   |

### **Special functions**

Pressing **PRINT** when there is no weight on the platter will advance a blank label.

Pressing **CONFIG** then **PRINT** will list the scale information on a label such as software version, IP address, MAC Address, scale type, scale ID, as well as the Product ID of the scale.

Power On while pressing Tare will show the IP Address

The 70 keys on the left keypad can be programmed as direct access keys (Presets). There are two levels to the preset keys for a total of 140 PLU Presets. The Preset keys should be configured first before being used.

To recall a PLU simply press the key once to access the Level 1 preset. To access the Level 2 Preset, hit the key twice. Alternatively, select the proper level by pressing the ↑ key to view L1 (Level 1) or L2 (Level 2) on the display, than press the desired Preset. The ↓ key provides PLU selection via item number.

Shortcut keys can also be programmed as quick access keys to particular setup functions.

- To set a key as a quick access key, go to the desired point in the setup menu and press MEM , then press the preset key, then press ENTER.
- To access the functional preset, press CONFIG then press the newly-appointed preset key.
- To clear a functional button, press MEM, clear and the desired preset button.
- Press ENTER to delete a shortcut key.

In addition, the Preset keys (Left side) also provide the QWERTY keyboard for whenever the scale allows text editing. These keys can be used as word processing keys while entering the PLU description, store address, Extra Text Ingredients, COOL statements, etc.

## Text Editing Mode

When editing text fields, the user will find the bPro very flexible. The buttons do double-duty when typing, allowing the previously defined functions to change toward a more language-friendly configuration (as seen below).

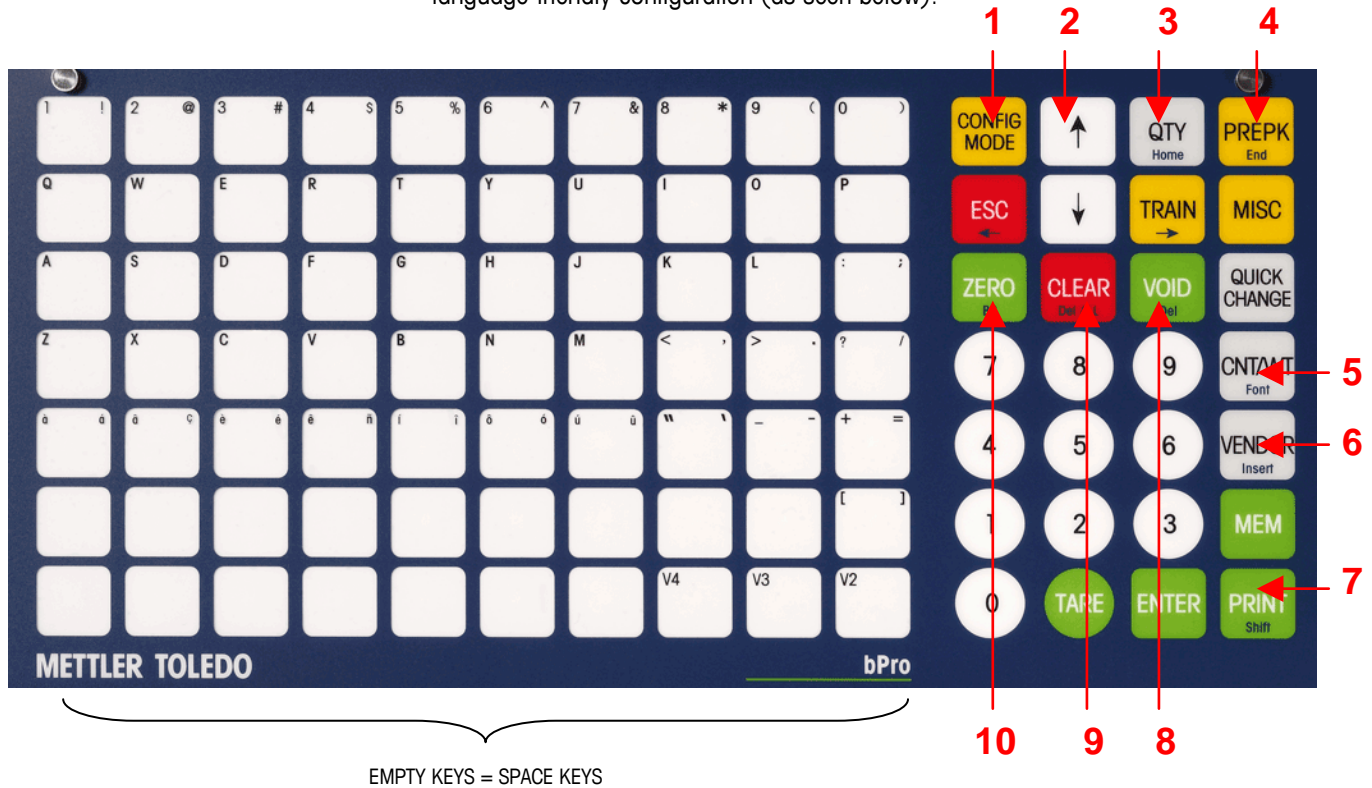

### Type Functions

- |    |  |
|----|--|
| 1  | Press <b>CONFIG</b> to escape text editing mode                                  |
| 2  | Navigation group – <b>ESC</b> moves cursor left, <b>Train</b> moves cursor right |
| 3  | Acts as home key to move cursor to the <b>beginning</b> of the line              |
| 4  | Acts as end key to move cursor to the <b>end</b> of the line                     |
| 5  | Font used to access <b>symbols, Unicode</b> or <b>Pin/YIN</b> characters         |
| 6  | Switch between <b>insert</b> and <b>overwrite</b> modes                          |
| 7  | Acts as <b>shift lock</b> to change between uppercase and lowercase keystrokes   |
| 8  | <b>Deletes</b> selected character  |
| 9  | <b>Clears</b> all text   |
| 10 | Acts as <b>backspace</b> to delete previous character                            |

### **Text Editing Window**

There are up to 15 lines per Text item. There can be multiple sentences per line. A line is a hard carriage return. To go to the next line, press the ↓ or ↑ keys. In each line the text will wrap in the allocated space as needed.



Bottom Left (Lower) shows the status of the Text.

Bottom Right (198) shows how many characters are remaining for that TEXT description.

In pressing Font (5 – CNT/WGT) while in Text Editing Mode, you can navigate through entering a Symbol, Unicode character or PIN YIN character

## Main Screen

Initially, the bPro boots to a screen that looks much like the one pictured below. This home screen allows for direct input of PLUs via the keyboard at the front of the unit as well as editing of various parameters that are attached to said PLUs. Depending on the PLU, this screen can take various forms (detailed below), with each containing an array of slightly-different fields.

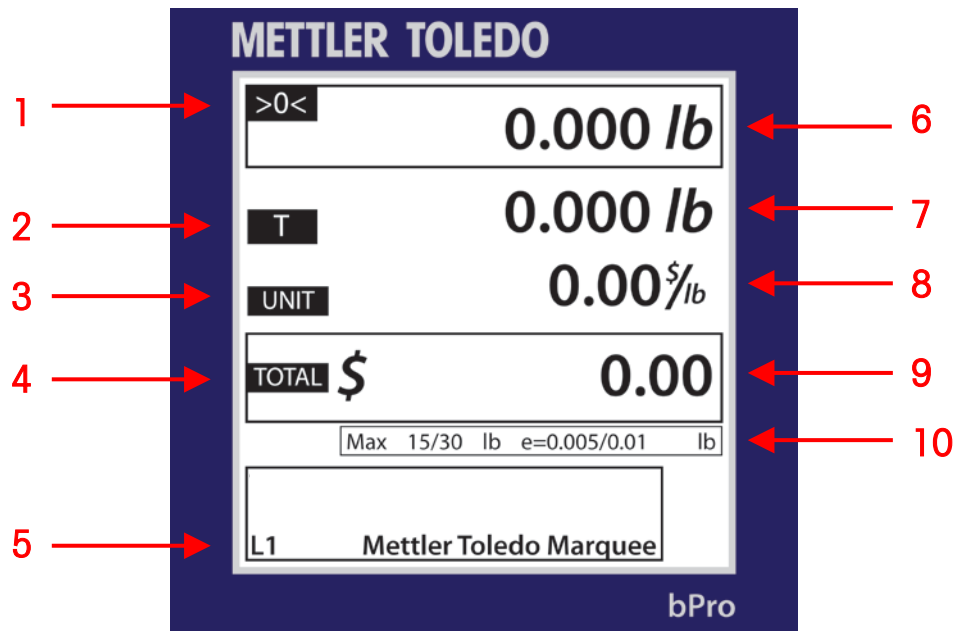

Operator Main Screen Components	
1	>0< indicates scale is at zero weight NET indicates scale is in net weight mode and a tare value is in use
2	Tare symbol
3	Unit price
4	Total price
5	L1 indicates Preset layer 1 will be used L2 indicates Preset layer 2 will be used
6	Platter weight display
7	Tare weight value being used
8	Unit cost of the specified PLU
9	Total price display value
10	Displays scale capacity and weighing increments as well as weight units



## PLU Pricing Modes

PLU is an abbreviation for **Price Look Up**. The PLU is a reference number assigned to a product's record including fields such as the description, price, tare, etc.

Different PLUs will have different pricing modes. Meat is normally sold "By Weight" by the pound or kilogram. Many bakery products are sold "By Count". Other products may be sold in a "standard package".

### By-Weight PLU

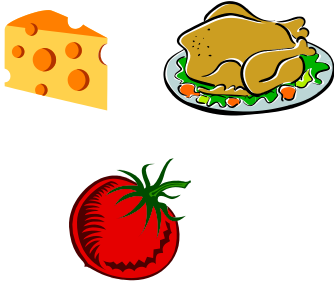

Examples of products sold **By Weight** are meats, cheese, poultry, and produce. By-Weight items can be priced in three ways:

Priced "Per Pound/kg" - Typically weighed items are priced per pound or kilogram. The weight multiplied by the unit price equals the total price of the product.

Priced "**Per Fraction of a Pound/Kg**" (fractional) - The item may be priced by the fraction of the pound or kilogram (where legal and desired). When the unit is calibrated in lb. mode,  $\frac{1}{4}$  and  $\frac{1}{2}$  pricing are available. In kg mode, 100 gram pricing is available.

"**Pounds/kilos for price**" - The PLU may be sold with a pounds-for-price (rather than price per pound). For example, "2 pounds for \$1.00" rather than "\$0.50/pound."

### By-Count PLU

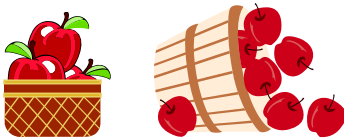

Examples of items sold by the count are cookies, donuts, rolls, bread, etc. Example: 4 Apples for \$0.69. Pricing is entered as a certain quantity of items for a set price.

### Standard Pack PLU



An example of an item sold by **Standard Pack** would be whole, precooked chickens, a sheet cake or a loaf of bread. These labels use a fixed net weight and total price for the item.

## PLU Screens

The **PLU screen** will vary based on the type of PLU that is being displayed: **By Weight**, **By Count** or **Standard Pack**.

**By Weight**

METTLER TOLEDO

>0< 2.170 lb

PT 0.005 lb

UNIT 3.49 \$/lb

TOTAL \$ 7.57

BYWGT Max 15/30 lb e=0.005/0.01 lb

Bavarian Style  
SIRLOIN STEAK

bPro

**By Count**

METTLER TOLEDO

COUNT 3 pcs

UNIT 1.06 \$/pcs

TOTAL \$ 3.18

BYCNT Max 15/30 lb e=0.005/0.01 lb

Naval  
ORANGE

bPro

**Standard Pack**

METTLER TOLEDO

NET 2.50 lb

COUNT 8 pcs

UNIT 1.76 \$/lb

TOTAL \$ 4.40

STDPA Max 15/30 lb e=0.005/0.01 lb

Baked Fresh Daily  
FRENCH BREAD

bPro

## Calling Up PLUs

When the bPro<sup>®</sup> is in Service Mode, the screen will display the Main PLU management array, from which all transactions may be conducted.

**Note:** "Service Mode" is normally the default on the PLU/PLU Edit screen. After the product has been weighed, a label has been printed and the item has been removed from the scale, the PLU will clear and the scale will return to the home screen, ready for the next item.

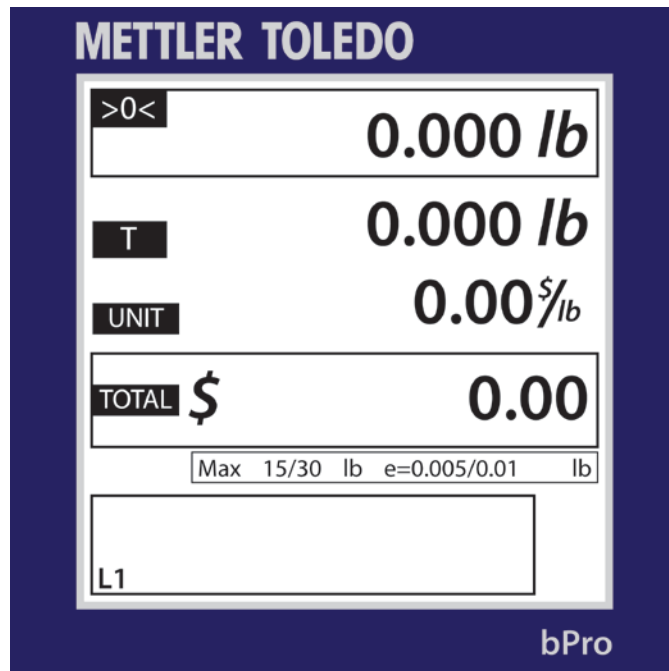

To begin a transaction, call up the PLU record by keying in the PLU number or pressing a Preset key. Depending on the scale's PLU auto call setting, the PLU record will be automatically called after entering a defined number of digits.

To use the Preset keys, it is possible to select Layer 1 or Layer 2 by using the up arrow. The default state is Layer 1.

For by-weight PLU, place the item on the weight platter; this can be done before or after a PLU number has been called. The machine will compensate depending on which method you choose.

Call up the PLU Record. To do this, find or key-in the Preset PLU related to the product. It may be a By-Weight, By-Count or Standard Pack item.

After keying-in the PLU, the screen will vary slightly in appearance depending on whether it is a By Weight, By Count or Standard Pack entry.

Depending on how the PLU has been set up, you may be able to edit some of the values for this current selection. If allowed, you can change items such as Shelf Life, Tare, etc by pressing the **Quick Change** button and navigating to the appropriate field. Any changes made will remain until the called PLU is overridden by pressing the clear button.

Quick changes are specific to the transaction and do not make permanent changes to the PLU record.

## Printing Labels

Once the PLU has been called up, make any needed changes, and then press the Print button on the keypad to print a label.



Take the label and remove the item from the scale to complete the transaction.

The bPro can be configured to be used in **Service Mode** or **Prepack Mode** depending on the needs of the user.

In **Service Mode**, once the PLU has been called, it will be necessary to press the PRINT key to get additional labels. The scale can be set for "Auto Clear" enable, whence it will clear out of the selected PLU after the label has been printed. If Auto Clear is disabled, then it will be possible to remove the first item, place a second item on the platter and then press the PRINT key to get a label for that item. Service Mode is the normal default mode.

In **Prepack Mode**, each time a new item is placed on the platter, a label will be printed (corresponding with a fluctuation in the weight on the platter). This mode allows for weighing multiple packages without pressing the PRINT key.

## Temporary Overrides

Temporary Overrides are certain values can be adjusted for the **current transaction** through the **Quick Change** button on the right center of the keypad. The changes are temporary – on a per-transaction basis, in other words – and will **NOT** be retained in the original PLU data.

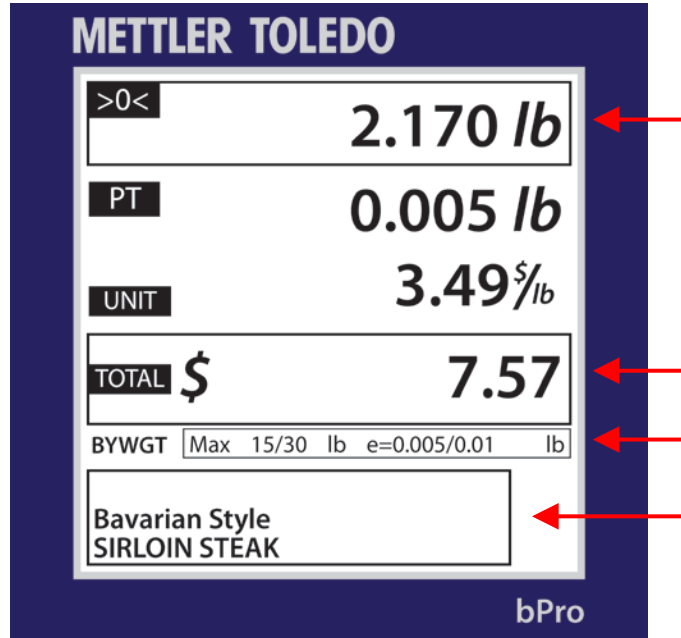

Depending on how the bPro has been configured, you may be able to perform **Temporary Overrides** on some of the PLU values for the current PLU. These include **Unit Price, Tare, Use By Date**, etc. The changes are temporary on a per-transaction basis and, thus, are NOT retained in the original PLU's dataset.

To change a value, call up a PLU and then press the **Quick Change** key. This will bring you to a scrollable list of the values that can be changed. Use the up and down arrows to navigate and then press the **ENTER** key to select the field to perform a temporary override. Enter the temporary value and then press ENTER to accept or **ESC** to not accept. Press the ESC key to get back to the PLU.

If the message **No Selection** is displayed, no fields have been enabled in the Quick Change setup menu. If only **Price Change** has been enabled, the Price Change menu will be displayed without going to the scrollable list.

# **METTLER TOLEDO**

**For your notes**

# 3

## Configuration

### Introduction

Setup for the bPro<sup>®</sup> is controlled from the **Configuration** screen. This is accessed by pressing the yellow **CONFIG MODE** button on the Operator keypad.



From here the Database, Print Report, Unit Setup, Service Mode, Password Setup and Clone Scale options can be accessed and modified.



At any time, the user may press ESC to return to the main transaction screen. Use the **↑** and **↓** arrows to scroll through the various options and press Enter to make a selection.

## Program Menu

### Database

Quick PLU Change  
 Quick Price Change  
 Quick Tare 1 Change  
 Quick Tare 2 Change  
 Quick use by date  
 Quick shelf life Change  
 Quick Extra Text 1  
 Quick Extra Text 2  
 Quick COOL Change  
 Quick Trace Lot Change  
 Quick Process Date  
 Quick Supplier Info  
 Quick Label Change  
 Quick Spec Message  
 Quick Nutrifact  
 Graphic 1  
 Graphic 2  
 COOL Production  
 COOL Country  
 COOL Pretext  
 TLV  
 Frequent Shopper  
 Database: PLU  
 Edit PLU – PLU Type, Item #, Dpt #  
 Description 1 – 4, Group, Price, Qty,  
 Fix WT, tare1/1%/2/2%, Shelf Life,  
 Use By, Spec Msg, Allow Price Chg,  
 ET, ET2, Label/PLU, Force Flag,  
 Blank Flag  
 Copy PLU  
 List PLU  
 Verify Labels  
 Edit PLU Added Items – NF, use SH, User  
 Graphic ½, COOL Text, COOL  
 production, COOL country, COOL  
 pretext, TLV, freq. shop type, Trace  
 Lot Nr, Trace Proc Date, Supplier  
 Info, 2nd Price  
 Copy PLU Added Items  
 Database: ET  
 Edit Extra Text  
 List Extra Text  
 Copy Extra Text  
 Database: Nutrifacts  
 Copy Nutrifacts  
 List Nutrifacts  
 Nutrifact Format  
 Database: Spec Message  
 Edit Special Message  
 List Special Message  
 Copy Special Message  
 Database Cool Text  
 Edit COOL  
 List COOL  
 Copy COOL

Database Traceability  
 Edit Lot Nr, Proc date, Supplier info  
 List Lot Nr, Proc date, Supplier info  
 Copy Lot Nr, Proc date, Supplier info  
 Database : Delete  
 – see items above  
**Unit Setup**  
 PLU Auto Call – Set Qty Digits  
 PLU Display Option – PLU Description  
 PLU Display Alignment  
 PLU Presets  
 Assign Presets – Manual, Auto  
 Delete All Presets  
 List Presets  
 List all Short Key  
 Active Tare  
 Default Label Format  
 By-Weight – Service, Prepack  
 By-Count – Service, Prepack  
 Standard Pack – Service, Prepack  
 Handbyweight – Service, Prepack  
 Handbycount – Service, Prepack  
 Total  
 Delete Custom Formats  
 Serial Port  
 Host Baud Rate  
 Host Data Bits  
 Host Parity  
 Host Stopbits  
 Host Timeout MS  
 Network  
 IP Address  
 Subnet  
 Gateway  
 MAC  
 Idle Time  
 Wireless Configuration  
 Store Information  
 Store Logo  
 Scale Number  
 Marquee  
 Bar Code Settings  
 Bar Code Number  
 Bar Type  
 Define Bar Code Digits  
 PLU Setting  
 Power Up – Service, Prepack  
 Print Mode – Print Key, After Motion  
 Auto clear  
 Back to zero  
 Set Time Date  
 Set - Date, Time  
 Format – Year, Time, Date Separator  
 Assign Group Name  
 Edit Group Name  
 Copy Group Name  
 Delete a Group Name  
 Delete All Group Names  
 List Group Names

Enable Function Keys  
 Enable- Void Key, Over-ride, Etc  
 Language  
 User Define  
 Display – Marquee, Tare, Screen Saver  
 Print Label Configure  
 Print Receipt Config  
 Print Paper Type – Receipt, Label  
 Sales Online  
 Process Mode  
**Service Mode**  
 Initialize Database  
 Reset Configuration  
 Assign Memory  
 Calibration – Press Cal switch  
 Price Format - Currency  
 Expand Wt Solution  
 Minimum Print  
 Digi Filter – Light, Heavy  
 Geo Code?  
 Load cell – Int, External  
 Weight Separator  
 Allow Fractional WT  
 Qty Label By Wgt  
 Calibrate  
 Label Printer Setup  
 Print Speed  
 Printer Dot Density  
 Strip Motor  
 Label Type  
 Enable Take-Up Sensor  
 Label Backup  
 Label Eject Length  
 Label Take-up Sensor  
 Test Printer Sensor  
 Printer Test  
 Receipt Printer Setup  
 Resistance  
 Print Speed  
 Printer Dot Density  
 Paper End Check  
 Test Printer Sensor  
 Printer Test  
 Function Tests  
 Display Test  
 Printer Test  
 Keyboard Test  
 Display Configuration  
 Contrast Adjust  
 Invert Background  
 History Path Grey  
 Beeper – On/Off  
 Debug  
 Serial Port Debug  
 Assert Debug  
 Predictive Maintenance  
 Print Head  
 Check Text  
 Print All Menus

### Print Reports

Reset to Default  
 Scale Total  
 PLU Total  
 Promote Total  
 Group Reports  
 Group Timely  
 Hourly Report  
 Settle Report  
 ST/VOID Report  
 Operator Report  
 Weekly Report  
 Monthly Report  
 Yearly Report  
 Combine Reports  
 Clear Reports  
 Clear Accumulator

### Password Setup

Change PW: Database  
 Change PW: Unit  
 Change PW: Service  
 Change PW: Password  
 Change PW: Quick Change  
 Change PW: Misc Key  
 Change PW: Training

### Clone Scale

Local - Remote  
 Remote - Local



## Database

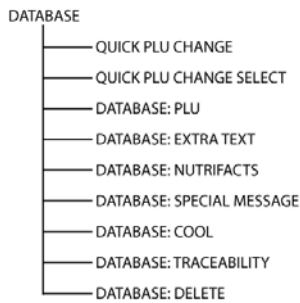

This path takes the user to the **Database** cascade where he or she may make changes to the individual PLUs.

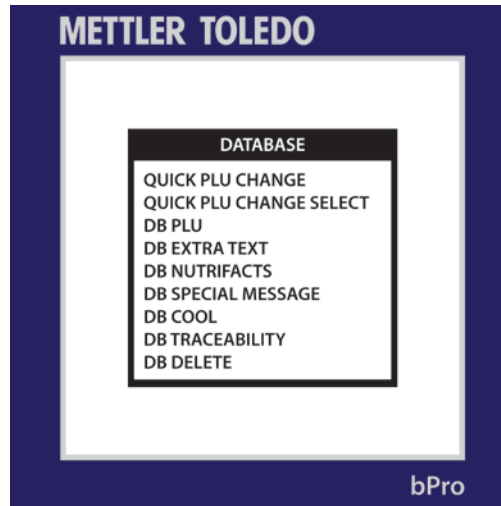

Use the **↑** or **↓** keys to make a choice. Press the **Enter** key to bring up the selected menu options or **ESC** to return to the main screen. They are as follows:

### Quick PLU Change

Use this menu to make permanent changes to selected PLU data. This menu allows easier access to PLU specifics without having to scroll through the massive list of parameters the user is otherwise faced with. Data is entered only for the specifically chosen PLU.

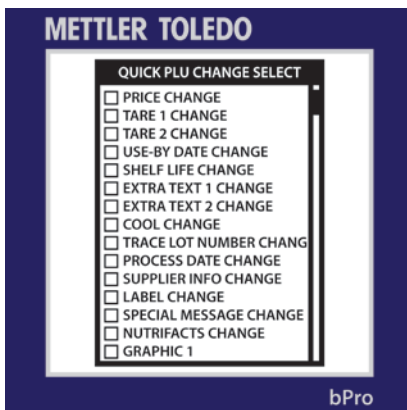

### Quick PLU Change Select (shown left)

Brings up a list of selectable options that can be toggled with the **Enter** key. Use the arrow keys to select fields from the list.

### DB PLU

This menu allows a user to make permanent changes to any and all PLU data. Data is entered for a specific PLU number.

### DB Extra Text

Add, edit, copy or list the extra text options for the selected PLU via linked record number

### DB Nutrifacts

Ability to copy or list embedded Nutrifact data to another link number. Also allows for the selection of the Nutrifact format.

### DB Special Message

Add, edit, copy or list the special message attached to the specified record number

### DB COOL

Add, edit, copy or list the COOL text attached to the selected PLU

### DB Traceability

Add, edit, copy or list a Traceability Statement with its linked record number for the Lot Number, Process Date or Supplier Information.

### DB Delete

Remove a record or all records of a type from the list. **WILL DELETE ALL DATA!**

## Quick PLU Change

QUICK PLU CHANGE

- QUICK PRICE CHANGE
- QUICK TARE 1 CHANGE
- QUICK TARE 2 CHANGE
- QUICK USE-BY DATE
- QUICK SHELF LIFE CHANGE
- QUICK EXTRA TEXT 1 CHANGE
- QUICK EXTRA TEXT 2 CHANGE
- QUICK COOL CHANGE
- QUICK TRACE LOT CHANGE
- QUICK PROCESS DATE
- QUICK SUPPLIER INFO
- QUICK LABEL CHANGE
- QUICK SPECIAL MESSAGE
- QUICK NUTRIFACT
- GRAPHIC 1
- GRAPHIC 2
- COOL PRODUCTION
- COOL COUNTRY
- COOL PRETEXT
- TLV
- FREQUENT SHOPPER

The **Quick PLU Change** menu is meant to allow for modification of the selected PLU with fewer keystrokes than if the user went through the other **Database** menus. By listing many of the most commonly changed categories in a head-to-tail fashion, the **Quick PLU Change** menu will likely become an off-visited destination for unit operators.

**NOTE:** Available list is configured via **Quick PLU Change Select**.

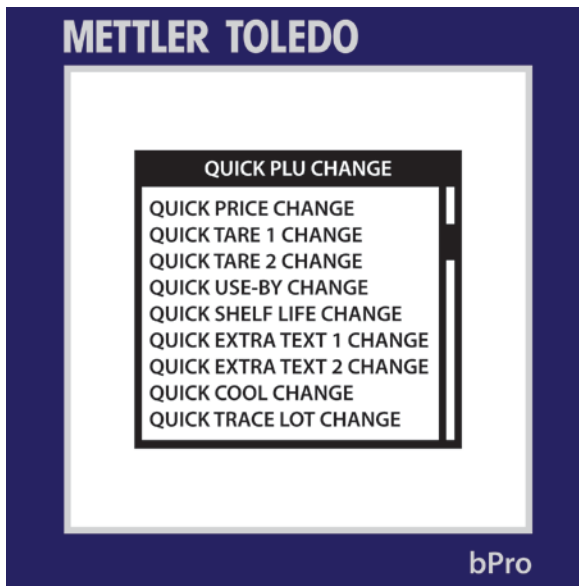

As should be evident by the list layout, the editable parameters are arranged in a more-or-less "most-often modified" order beginning with Price Change and moving outward both up and down. A complete list of the categories follows.

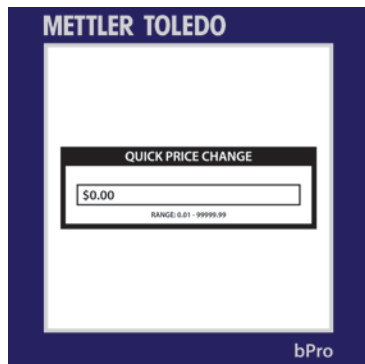

**Quick Price Change** (shown left; all screens in this category follow this layout)  
Change the selected PLU's unit price

**Quick Tare 1 and Tare 2 Change**  
Change the selected PLU's tare weight. The below screen is representative of the data-entry fields used in the rest of the screens in this cascade.

**Quick Use-By Date Change**  
Change the selected PLU's Use-By date. Should only be modified for new products.

**Quick Shelf Life Change**  
Change the selected PLU's shelf life.

**Quick Extra Text 1 and 2 Change**  
Change the selected PLU's primary and secondary extra text entries.

**Quick COOL Change**  
Enable, disable or modify the selected PLU's COOL information.

**Quick Trace Lot Number Change**  
Enable or disable the selected PLU's trace lot number functionality

**Quick Process Date Change**  
Change the selected PLU's process date

**Quick Supplier Info Change**  
Change the selected PLU's supplier information

**Quick Label Change**

Change the selected PLU's first and second label printing characteristics

**Quick Special Message Change**

Add or modify the selected PLU's special message(s)

**Quick Nutrifacts Change**

Change the selected PLU's Nutrifacts

**Graphic 1**

Assign a graphic number to the first graphic field on the label

**Graphic 2**

Assign a graphic number to the second graphic field on the label

**COOL Production**

To be implemented in a future software version

**COOL Country**

To be implemented in a future software version

**COOL Pretext**

To be implemented in a future software version

**TLV**

To be implemented in a future software version

**Frequent Shopper**

Allow frequent shopper option to be used

---

## Database PLU

The **Database PLU** cascade allows for fine-point editing of the available PLUs. From here, a user will be able to do everything from simply listing all available products to verifying the labels assigned to each PLU to actually modifying which products correspond to which PLU numbers.

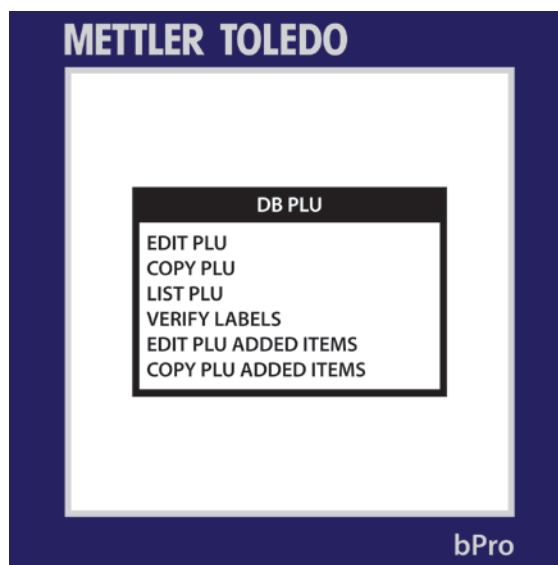

A breakdown of the individual categories follows.

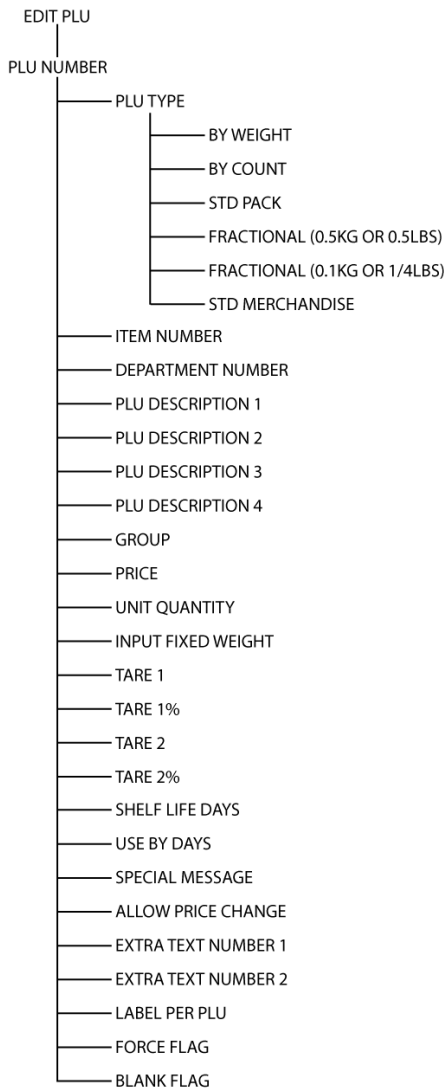

## Edit PLU

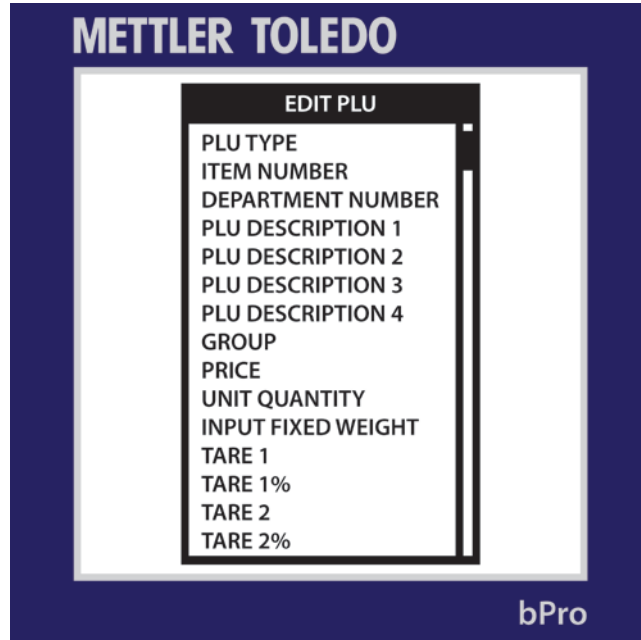

Via the **Edit PLU** menu, a user may completely redefine a product entry. Listed in a continuous loop are the categories PLU Type, Item Number, [4] Description lines, Group, Unit Price, Unit Quantity, Input Fixed Weight, Tare, Shelf Life (days), Use-By (days), Special Message text, Extra Text Number and Labels per PLU.

Within this area, you may also set permissions for price changes to the specified PLU.

### Copy PLU

Creates a redundant entry of the selected PLU within the database under a new PLU number

### List PLUs

Prints a list of consecutive PLUs with their product designations. The user may select the range of PLUs which will be printed, i.e. 1 – 6 or 650000 – 655000.

### Verify Labels

Prints a series of labels to verify the format and number as per the PLU data

### Edit PLU Added Items

This menu allows the user to edit and otherwise modify any of the added parameters of the PLU. These parameters include **Nutrifact**, **Safe Handling**, **Graphics 1&2**, **COOL Text**, **Frequent Shopper Type**, **Traceability**, **Trace Process**, **Supplier** and **Second Price**.

### Copy PLU Added Items

As with the **Edit PLU Added Items** menu, this one deals with the extraneous bits of data attached to the specified PLU. Through this menu, a user can clone entries for use in other PLUs

---

## Database Extra Text

The **Database Extra Text** menu is responsible for the modification of existing extra text entries as well as the addition of new ones.

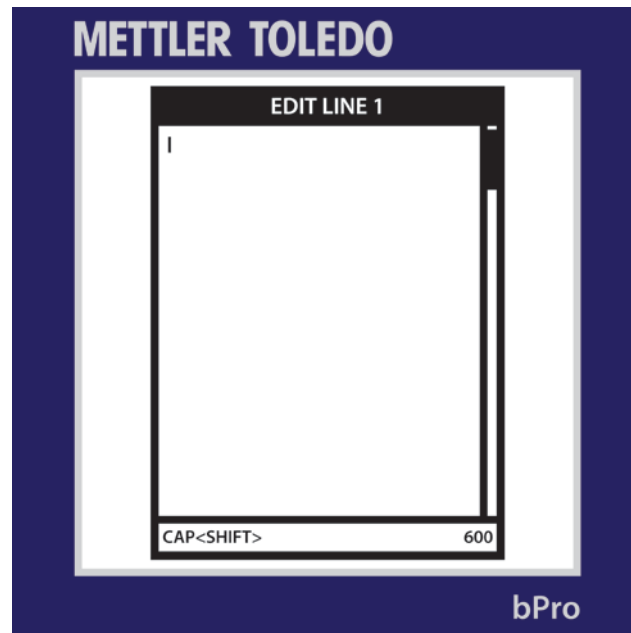

A user may use this cascade to make changes to any of the extra text entries in the system. Simply enter an entry number and add text until satisfied.

Refer to Chapter 2, **Text Edit Mode**, for text edit key functions.

Press **Enter** when complete.

## Database Nutrifacts

In order to best use the **Database Nutrifacts** menu, the user should be familiar with the process of assigning numbers to and modifying Nutrifact entries.



### Copy Nutrifacts

Allows the user to duplicate a Nutrifacts entry for use in another PLU

### List Nutrifacts

The user selects a range of Nutrifact entries which the machine then prints on whatever label stock it has available. Useful for cataloguing purposes.

### Nutrifacts Format

This menu enables the user to select between various Nutrifact formats depending on the part of the world in which the scale resides.



The choices are shown above and can be selected with the arrow keys and the **Enter** key.

---

## Database Special Message

The **Database Special Message** menu allows the user to alter, copy or list-print the special messages in the system memory.



Simply choose which path you'd like to take and press **Enter**. As per the previous menus, the **Edit** function allows the user to modify existing messages; the **Copy** command duplicates the existing information for use elsewhere and the **List** function prints a run of the current messages within a user-selected range.

---

## Database COOL Text

This menu allows the **Database COOL Text** to be modified along the same lines as the extra text and special messages detailed above. As such, the same protocol applies.



Press **Enter** when finished.

## Database Traceability

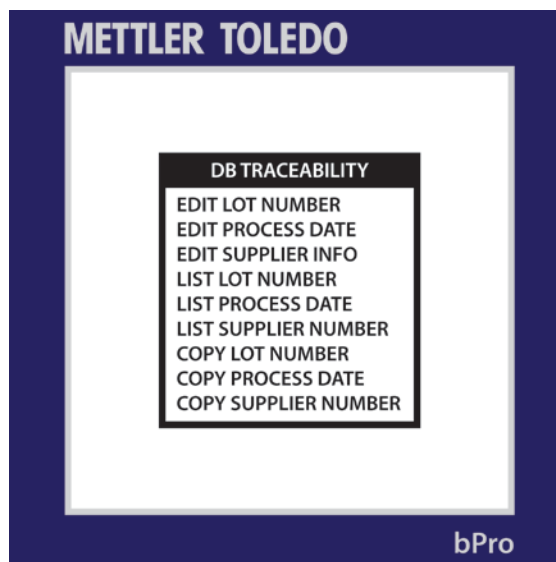

### **Edit Lot Number; Edit Process Date; Edit Supplier Information**

Upon entering any of these three arrays, the user will be prompted to type in the number of a specific entry. After that, a text window will appear wherein he may edit or add to any of the information contained within.

Press the **Enter** key when finished and **Escape** to back out to the main **Traceability** menu.

### **List Lot Number; List Process Date; List Supplier Information**

Selecting among these three menus will allow the user to print a range of the queried data on whatever label stock is available.

### **Copy Lot Number; Copy Process Date; Copy Supplier Information**

Each of these menus works in the same way. The unit operator selects the number of a current entry, selects a new number for the duplicate entry and hits **Enter**. From that point on, the new number will reference a data string identical to the copied bit.



## Database Delete

As one might expect, this menu is used to permanently delete entries from the unit database.

**CAUTION! UNLESS YOU HAVE A BACKUP OF YOUR DATABASES, THEY WILL BE LOST UPON EXECUTION OF THIS COMMAND. BE SURE YOU ARE PREPARED BEFORE DELETING ANY DATA.**



As the names would suggest, the **Delete All** \_\_\_\_\_ entries revolve around emptying the database completely of those data strings.

The more-specific **Delete A** \_\_\_\_\_ are for the precision elimination of single entries within each heading. As is the case with the editing and management of PLUs and PLU data bits, simply key in the number of the **PLU**, **Extra Text** entry, **Special Message**, etc. and choose to delete it.

No deletions should be made before a complete and known-working backup image of the scale is on hand, as deleted entries cannot be retrieved once erased.

## Clone Scale

**DISCLAIMER:** The **Clone Scale** function is meant to be used by trained Mettler-Toledo technicians **ONLY**. Failure to properly execute the process will result in an unusable product and the scheduling of a service call.

---

## Print Reports

**DISCLAIMER:** The **Print Reports** function is meant to be used by trained Mettler-Toledo technicians **ONLY**. Failure to properly execute the process will result in an unusable product and the scheduling of a service call.

---

## Service Mode

**DISCLAIMER:** The **Service Mode** functions are meant to be used by trained Mettler-Toledo technicians **ONLY**. Failure to properly execute these processes will result in an unusable product and the scheduling of a service call.

---

## Password Setup

**DISCLAIMER:** The **Password Setup** function is meant to be used by trained Mettler-Toledo technicians **ONLY**. Failure to properly execute the process will result in an unusable product and the scheduling of a service call.

## Unit Setup

### UNIT SETUP

- PLU AUTO CALL
- PLU DISPLAY OPTIONS
- PLU DISPLAY ALIGN
- PLU PRESETS
- ACTIVE TARE
- DEFAULT LABEL FORMAT
- DELETE CUSTOM FORMATS
- SERIAL PORT
- WIRELESS
- STORE INFORMATION
- STORE LOGO
- SCALE NUMBER
- MARQUEE
- BARCODE SETTINGS
- PLU SETTINGS
- SET TIME AND DATE
- ASSIGN GROUP NAMES
- ENABLE FUNCTION KEYS
- LANGUAGE
- USER DEFINE
- SALES ONLINE
- PROCESS MODE

The **Unit Setup** menu contains many of the options necessary to tune the bPro unit to a user's specific needs. To access it, the user will need to press the **Config Mode** button on the keypad and cycle past the **Database** and **Print Reports** options.

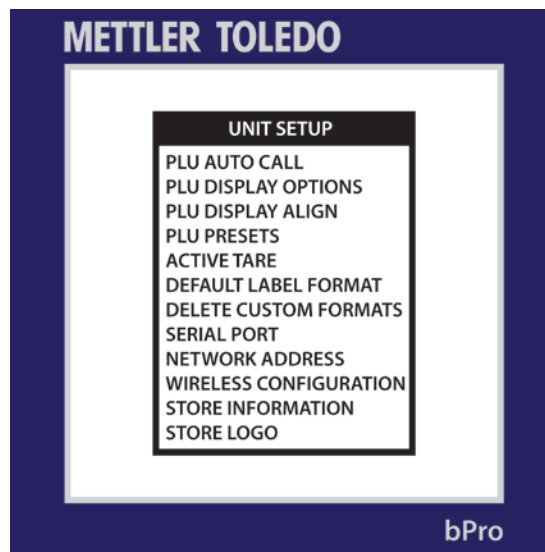

The various submenus of the **Unit Setup** main screen are listed below with short descriptions; that you may go immediately to the area concerning your needs.

#### **PLU Auto Call**

Set the auto call limit – the number of digits entered before the database is searched for a corresponding PLU of that number.

#### **PLU Display Options**

Select between the various PLU display options (L1, L12, L24, etc.) as well as which PLU lines to display

#### **PLU Display Align**

Choose either left or center alignment for the PLU display

#### **PLU Presets**

Manage presets via modification, assignment, deletion and listing

#### **Active Tare**

Denote whether Tare 1 or Tare 2 will be applied to the PLU

#### **Default Label Format**

Select the default label format to be used for the different modes of operation.

#### **Delete Custom Formats**

Used to delete all custom formats that exist in the scale. **IRREVERSIBLE**.

#### **Serial Port**

The user may view and modify the port information via this menu

#### **Network Address**

View all manner of IP, Network, Subnet, MAC, etc. addresses assigned to the scale unit

#### **Wireless Configuration**

Configures the wireless card, if installed

**Store Information**

Edit the store info text field. This data is printed on the label in the field of the same name. Typically includes store location and addresses.

**Store Logo**

Use this menu to select a specific store logo from the list of uploaded graphics

**Scale number**

Select a network identification number for the scale

**Marquee**

Use this menu to make changes to the scrolling marquee text

**Barcode Settings**

Define the style and specifics of the unit's barcode recognition and printing

**PLU Settings**

Configure **Power-Up Mode**, **Prepack Print Mode**, **Auto Clear** and **Back to Zero**.

**Set Time and Date**

Specify the time and date

**Assign Group Names**

Modify, copy, delete or list the group names available on the scale

**Enable Function Keys**

Enable or disable the various function keys on the keypads

**Language**

Select the scale's displayed language

**User Define**

Modify the settings for the bPro display as well as the parameters for the printer

**Sales Online**

Enable or disable the sales online application

**Process Mode**

Enable/Disable process mode feature and configure process mode parameters

---

## PLU Auto Call

The **PLU Auto Call** menu allows the user to determine how many keystrokes will be required to be entered before starting a PLU search.

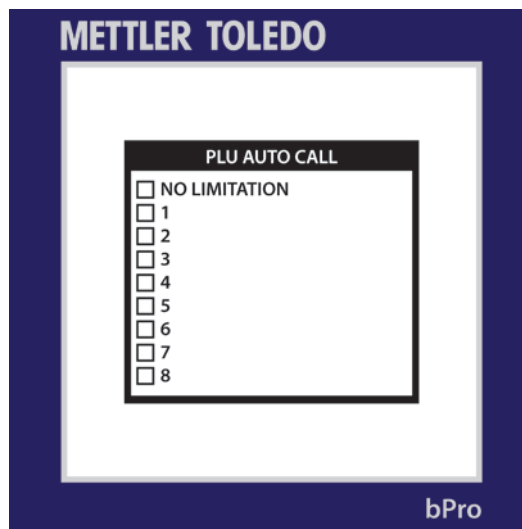

Setting the number at one, for example, will allow a user to press one on the keypad and have the database pull up the corresponding PLU. Conversely, if the number is set to six, the unit will not automatically bring up data corresponding to a PLU until either a.) all six of the PLU's digits are entered or b.) the **Enter** key is pressed after a smaller PLU string is keyed in.

---

## PLU Display Options

To change the layout of the PLU descriptions on the scale display, the user will need to visit the **PLU Display Options** menu.

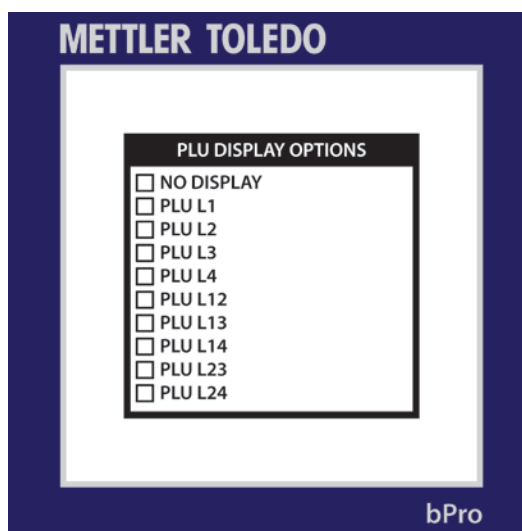

Up to **TWO** lines of PLU description may be displayed on the PLU edit screen. Select which lines to show and in what order to display them.

## Active Tare

Selects whether Tare 1 or Tare 2 will be used when a PLU is called.

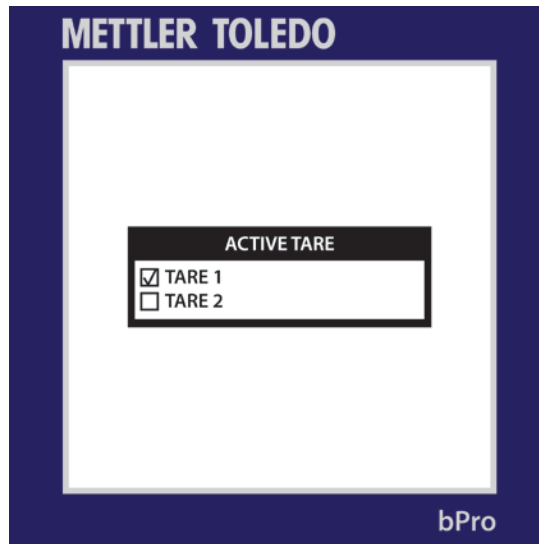

---

## PLU Display Align

Simply put, the **PLU Display Align** menu allows the user to choose whether the PLU description text will be left aligned or centered on the PLU screen. Use the arrow keys to move the cursor and press **Enter** to make a selection.



## PLU Presets

The PLU Presets menu allows the user to assign PLUs to the left-hand keys on the bPro keypad.



In manual mode, the user selects particular PLUs to assign to the first and second levels of each button (as desired). This is simply done by pressing a preset button and then keying in a PLU number. Repeat as necessary.

Automatic assignment takes the first 140 PLUs in the database and assigns them in sequence, 1-70 and 71-140, to levels L1 and L2 respectively.

## Default Label Format

In the name of efficiency, the label formats are easy to change with a quick glance at the **Default Label Format** menu. Here a user is able to choose the particulars of the default label format for each of the various scale modes.

**NOTE:** within each label format, it is possible to define a label number. Refer to chapter 4 for a table of the default label formats and their numbers.

If the stock label types are not adequate, you may use a custom label format number to define a particular setup that has been added to the system.

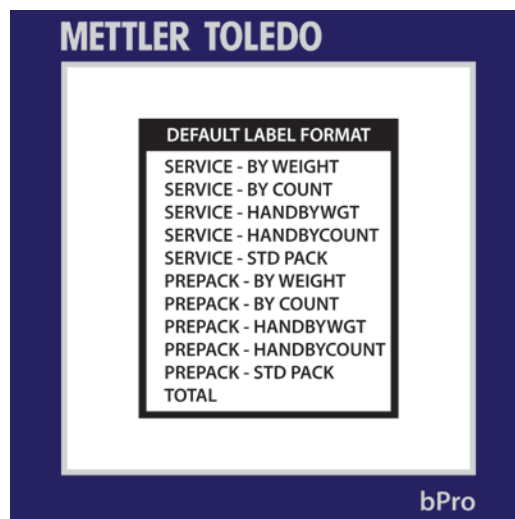

Within each label submenu, the user will be able to enable various switches such as **Print Pack Date**, **Print Sell-By Date**, **Print Use-By Date**, etc. Simply use the arrows to select yes or no for each and press **Enter** to change between selections. Hit the **ESC** key to exit after making your choices.

---

## Delete Custom Formats

This option allows you to delete the custom label formats in the database. Select yes or no on the popup.

**WARNING!** Once you select **YES**, all of your custom label formats will be deleted. There is no recovery function, so be sure this is something you wish to do.

---

## Serial Port

The **Serial Port** menu allows the User to view and modify (within ranges) the serial communication parameters of the bPro unit.

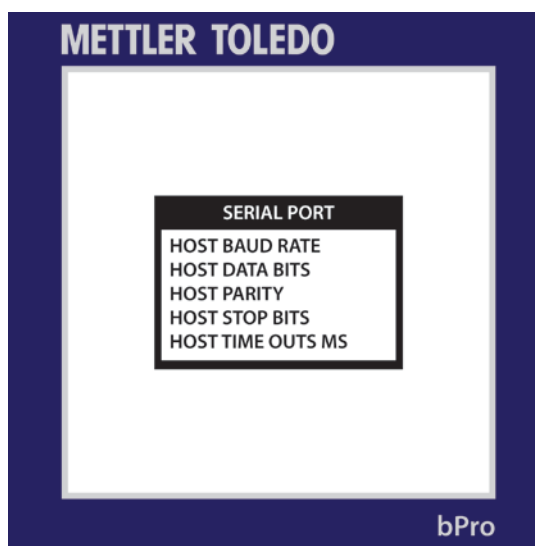

### Host Baud Rate

The user may select from a variety of choices within the range of 300 – 115200.

### Host Data Bits

Select between five, six, seven or eight

### Host Parity

Either "None", "Even" or "Odd" at the user's discretion

### Host Stop Bits

The user may select either one or two

### Host Timeouts (in milliseconds)

The timeout can be set to anything the user desires. Be sure to input the choice in milliseconds and not base seconds.



## Network Address

To check the various address specifics of the unit, a user needs simply go to the **Network Address** menu. Here they will find a list of the current addresses attached to the machine and its immediate network(s).

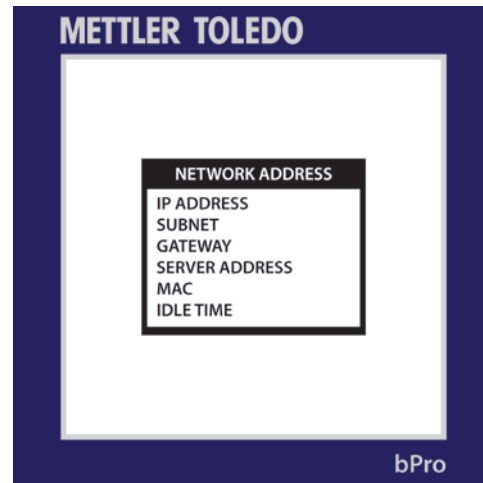

After toggling to **NETWORK**, press the ENTER key. Use the up/down arrows to toggle between **IP ADDR**, **SUBNET**, **GATEWAY**, **MAC** Address, and **IDLE TIME**. The MAC address selection is for information only and cannot be changed. Press ESC key to exit and then ENTER to save the setting.

### IP ADDRESS

Press ENTER at **NETWORK** to display the current scale IP address. The IP Address identifies the client on the network. The IP Address is a unique number consisting of four parts separated by periods (Ex: 146.207.40.1).

To change the IP Address, press ENTER, and then enter the new IP Address. The IP address is entered one octet at a time. The default value for this field is 255.255.255.000.

### SUBNET

The Subnet Mask is used to identify the local network when accessing IP address on the Ethernet network. The mask is entered one octet at a time. The default value is 255.255.255.000.

### GATEWAY

Gateway Router IP address is used when accessing devices outside of the local network. The IP address is entered one octet at a time. The default value is 255.255.255.000.

### SERVER ADDRESS

Displays and allows for modification of the server's IP address.

### MAC

This is the hardware MAC (Media Access Control) address. The MAC address will be displayed but cannot be changed. It will display 6 sets of 2 numbers that start with 00:E0:7C:xx:xx:xx. The last 6 digits will vary with each scale.

### IDLE TIME

This is the time (measured in seconds) that the bPro will wait after no communication before it closes an Ethernet socket connection.

---

## Wireless Configuration

This section allows you to set up your wireless device via a few simple switches –

Wireless CONFIG to ON or OFF

Set default number to ON or OFF

Set Auto IP to ON or OFF

Enter SSID

Enter Infrastructure

---

## Store Information

The **Store Information** menu allows the user to type out a description or catch phrase associated with their store. Simply use the keypad to enter a message or statement and then press Enter. This text will be printed on labels using the store info field.

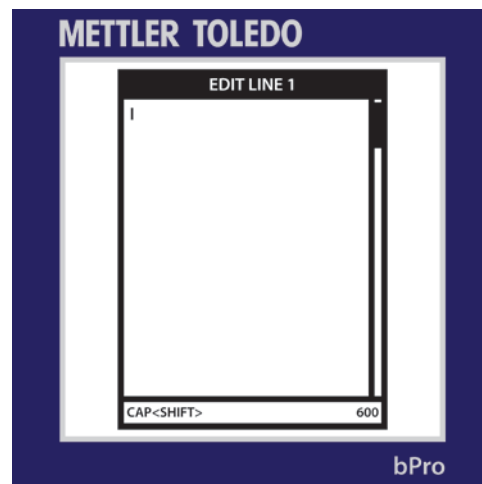

---

## Store Logo

To select a **Store Logo** that will print on many of the unit's labels, a user must simply make a selection from the database of uploaded images. Key in the number of your choice and press **Enter** to apply the graphic to the appropriate functions.



---

## Scale Number

The Scale Number menu allows the user to quickly identify a unit on the network. The selection of scale numbers is 1 – 255.

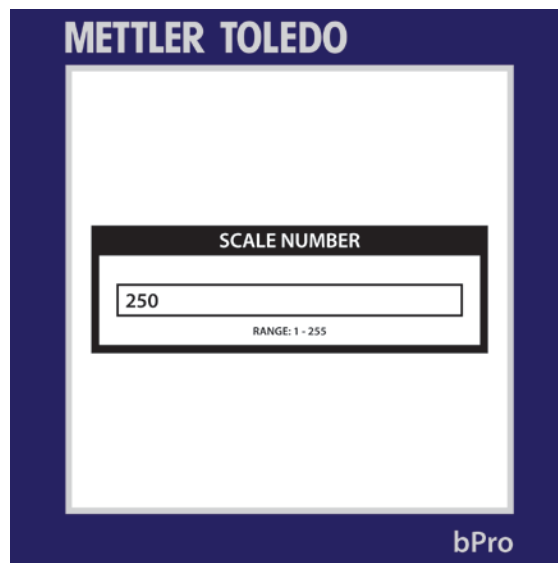

## Marquee

A user may enable or modify the marquee features of the bPro by accessing the **Marquee** menu in the Unit Setup cascade. As with the other user-friendly menus, one simply follows the intuitive menus to choose when the marquee begins to scroll, how fast it moves across the screen and what exactly it says.

Press **Enter** when finished with each section.

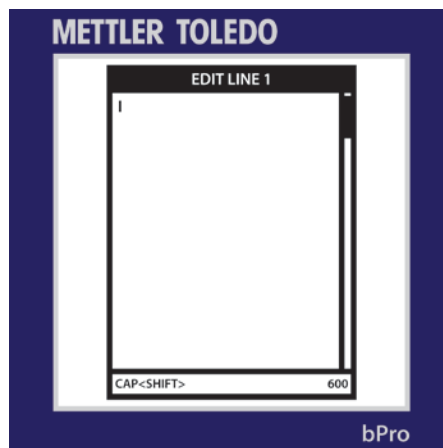
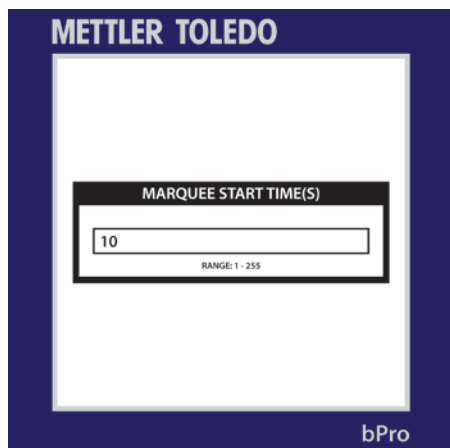

## Barcode Settings

In the **Barcode Settings** menu, the user can not only select the format of the barcodes that will be produced on every receipt, but also the specific digit-definitions for those barcode strings\*. As with all other bPro menus, simply navigate up and down with the arrow keys and press **Enter** to make a selection.



When finished, the **ESC** button will take you back to the main **Unit Setup** screen.

\*See **Define Barcode Digits** in the appendix for more information

## PLU Settings

The **PLU Settings** menu allows the user to select what mode the scale will boot into as well as the label printing configuration when in prepack mode. Also included are the options to set **Auto Clear** and **Back to Zero** (which affect the weighing conventions between placement of product on the weigh platter or after printing of a label).

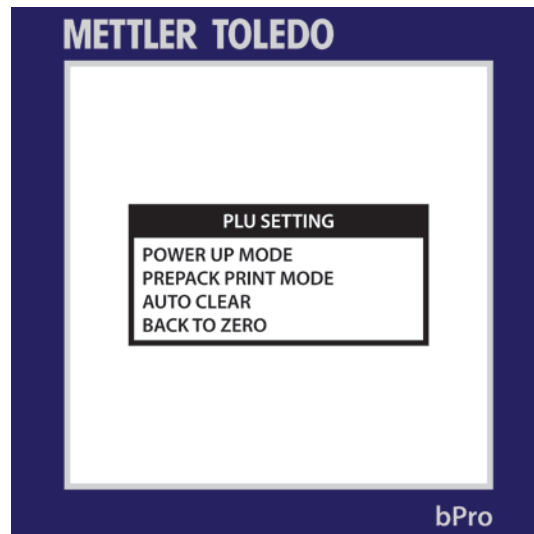

Power-up modes include **Service**, **Prepack** and **Last**.

The prepack printing modes include **Auto** and **Manual**.

**Auto Clear** is a toggle which requires the scale to return to the ready screen after a label is printed

**Back to Zero** requires that the weigh platter be vacated and reloaded between printings.

## Set Time and Date

As its name suggests, the **Set Time and Date** menu deals with synchronizing the scale to the current time and date. Here the user may also select such trivialities as formatting of the individual values and the punctuation marks separating the fields.

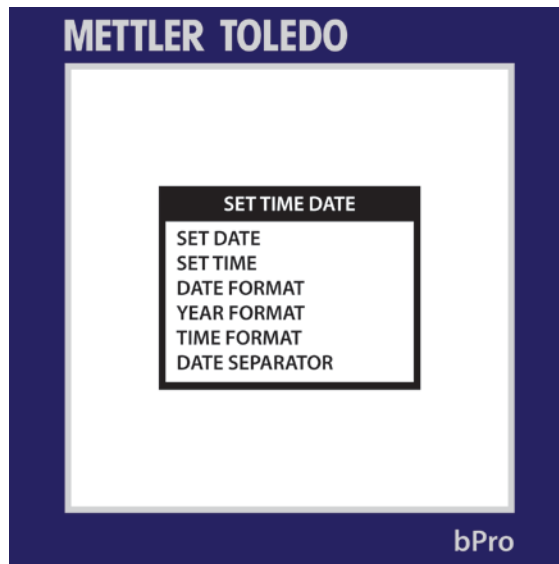

Press **ESC** when finished.

---

## Assign Group Names

The **Assign Group Names** menu array deals mainly with the management of existing groups with an allowance for copying complete groups to new numbers.



---

## Enable Function Keys

This menu allows the user to set the functionality for each of the unit's keys. The individual keys can be switched on or off for users of a certain permission level. Pressing **Enter** toggles the key on or off.

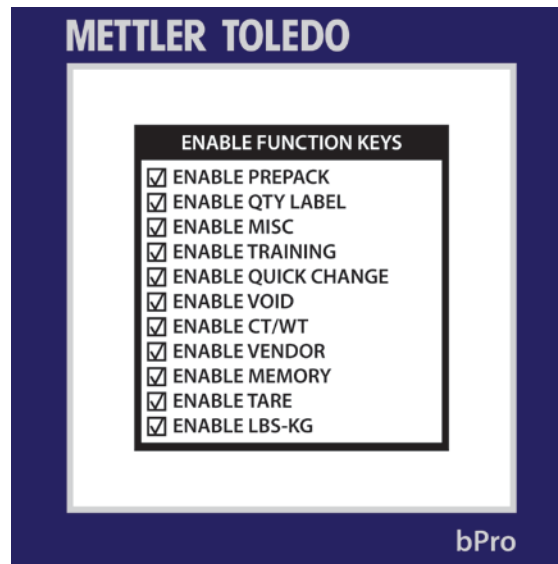

Press the **ESC** key when finished making changes.

---

## Language

The **Languages** menu allows the user to choose the language in which all unit text will be displayed. Simply use the arrow keys and press **Enter** to confirm your choice. Pressing **ESC** exits the screen.

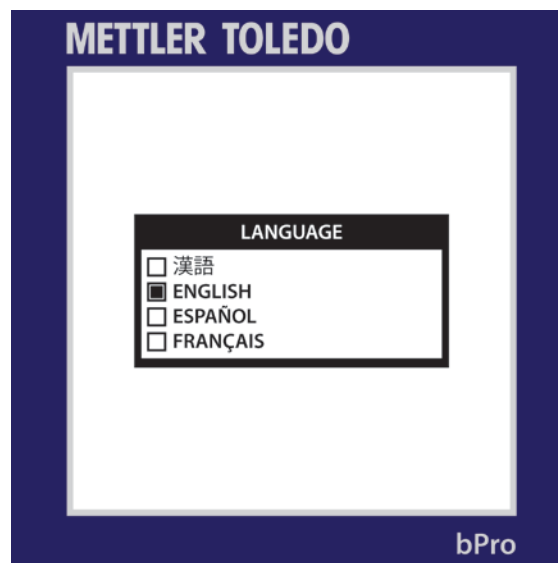

## User Define

The **User Define** menu allows various parameters to be changed that dictate the appearance of the display screen and various printed materials. Select a category and press **ENTER** to see more menus.

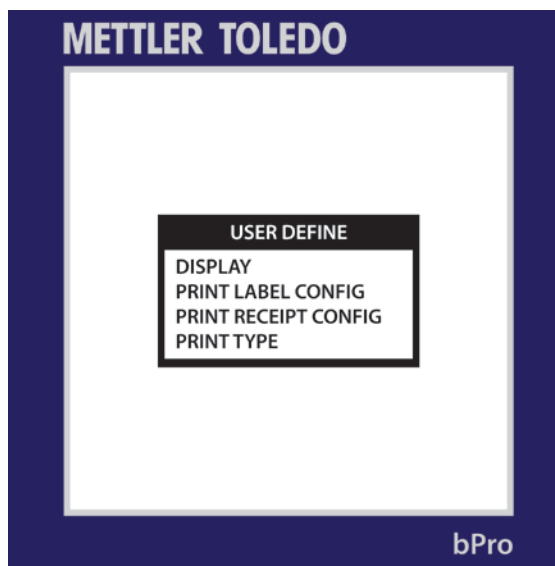

**Display** – allows the user to determine whether or not the marquee, tare and screen saver will be displayed. Should the screen saver be enabled here, further menus will appear wherein the user may choose the clock or picture (selected from list) as well as the activation time delay (from 1 – 255 seconds).

Pressing **ENTER** selects/deselects and pressing **ESC** advances the menus without making changes and will eventually return you to the main User Define screen.

See the bPro Service Manual for more details.

**Print Label Configuration** – the user may define what prints on the label within the following list: PLU number, store name, header, footer, stub, barcode (stub or receipt) and total weight. **ENTER** toggles, **ESC** cancels.

**Print Receipt Configuration** – the user may define what prints on the receipt within the following list: PLU number, store name, header, footer, stub, barcode (stub or receipt) and total weight. **ENTER** toggles, **ESC** cancels.

**Print type** – select what will print at the end of a transaction: receipt mode, label mode receipt + total, total.



---

## Sales Online

**SALES ONLINE** is a scale application that allows floating vendor functionality where multiple PLU transactions are placed on one label or receipt. The Sales Online application will communicate the transaction list to the POS system. The Sales Online Scale application needs to work with the Sales online Server software (external application not included with the scale). By selecting Enable, the scale will look to communicate with the server software application, and send the transactional data as required.



Press **Enter** to choose and **ESC** to unpack the corresponding menu tree. Upon selection of either choice, the following options will appear, able to be modified per necessity.

**Offline Barcode** – select a number for the PLU's offline barcode.

**Online Barcode** – select a number for the PLU's online barcode.

**Label print Direction** – choose between normal and convert, which will print label information top-to-bottom or bottom-to-top, respectively.

**Department Number** – select a number for the PLU's department.

**UPC Number** – select a number for the PLU's UPC.

## Process Mode

The **Process Mode** menu allows the user to designate PLUs as certain types, thus assigning them certain barcode formats, by way of transaction.

When this option is enabled, the user will be prompted to select from the five choices listed. Once chosen, the user will have the option of renaming the category per the barcode number (format style) they select.

The window that houses the five choices can be brought up at any point in the PLU editing process by pressing the **MISC** button on the keypad.

Once a selection is made, successive PLU transactions will acquire the barcode format assigned to the initial PLU. In order to avoid this, if you do not wish a string of PLUs to be specifically branded, simply disable Process Mode.

# 4

## Labels

### Loading Labels

**NOTE:** A label loading diagram can be found on the printer for quick reference.

**NOTE:** When changing a label roll, always look for any buildup. See Chapter 5 for cleaning procedures.

The bPro label loading procedure is a simple one and can be worked through by any user who reads the following section.

- 1.) Open the printer door by pressing down on the release tab.



- 2.) Pull the printer out using the green pull-tab.



3.) Unlock the printhead by pressing on the green lock-lever.



4.) Install the label roll on the supply spool and remove about 6 inches of labels from the liner. Slide the labels under the guides and printhead as shown in the illustration.



5.) Pull the liner back and route it under the bottom guide. Gently pull out on the green knob on the liner take-up spool (1) and then slide the liner into slot in the roller (2).

**NOTE:** The green knob does not come all the way out! Do not use excessive force to pull out on the green knob! Using excessive force to push the knob in can result in broken locking tabs on the green knob.



6.) Gently push in on the green knob to lock the liner into place, and then turn the roller clockwise to take up some of the slack in the liner.

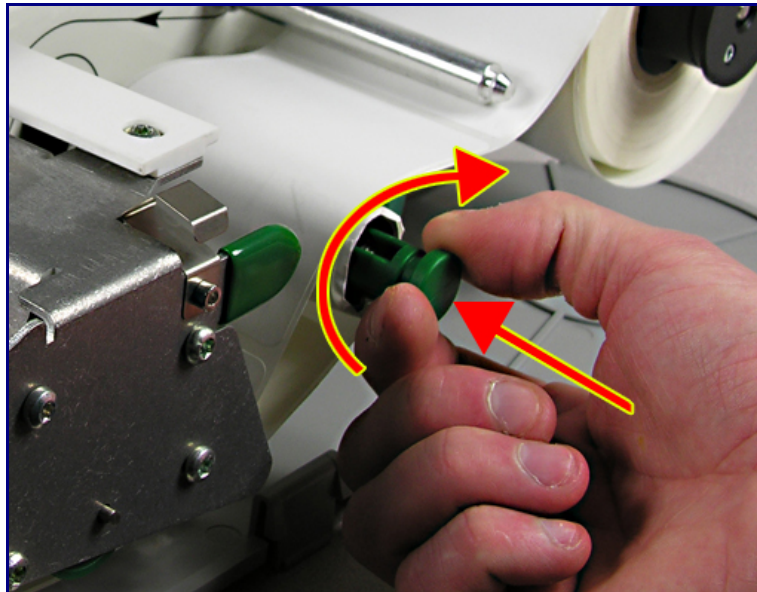

7.) Press down on the printhead latch until it locks down.



8.) When the printer has been loaded with properly installed labels, as below, push the printer back in and close the door.



## Default Label Styles

Below is a list of default label styles broken into their default numbers (left column) and a description of their size and function (right column).

Bolded text has been used to differentiate label styles based on common size.

Default Label Format Number	Label Format Name
101	48_ByWgt_SellBy.blbl
102	48_ByCnt_SellBy.blbl
103	48_StdPack_SellBy.blbl
104	48_ByWgt_PackDate.blbl
105	48_ByCnt_PackDate.blbl
106	48_StdPack_PackDate.blbl
<b>110</b>	<b>53_ByWgt_SellBy.blbl</b>
<b>111</b>	<b>53_ByCnt_SellBy.blbl</b>
<b>112</b>	<b>53_StdPack_SellBy.blbl</b>
<b>113</b>	<b>53_ByWgt_PackDate.blbl</b>
<b>114</b>	<b>53_ByCnt_PackDate.blbl</b>
<b>115</b>	<b>53_StdPack_PackDate.blbl</b>
120	60mmByWgt_SellBy_BCtop.blbl
121	60mmByCnt_SellBy_BCtop.blbl
122	60mmStdPack_SellBy_BCtop.blbl
123	60mmByWgt_SellBy_BCmid.blbl
124	60mmByCnt_SellBy_BCmid.blbl
125	60mmStdPack_SellBy_BCmid.blbl
126	60mmByWgt_SellBy_ET_BCtop.blbl
127	60mmByCnt_SellBy_ET_BCtop.blbl
128	60mmStdPack_SellBy_ET_BCtop.blbl
129	60mmByWgt_SellBy_ET_BCmid.blbl
130	60mmByCnt_SellBy_ET_BCmid.blbl
131	60mmStdPack_SellBy_ET_BCmid.blbl
<b>140</b>	<b>84mmByWgt_SellBy_ET_BCtop.blbl</b>
<b>141</b>	<b>84mmByCnt_SellBy_ET_BCtop.blbl</b>
<b>142</b>	<b>84mmStdPack_SellBy_ET_BCtop.blbl</b>
<b>143</b>	<b>84mmByWgt_SellBy_ET_BCmid.blbl</b>
<b>144</b>	<b>84mmByCnt_SellBy_ET_BCmid.blbl</b>
<b>145</b>	<b>84mmStdPack_SellBy_ET_BCmid.blbl</b>
<b>146</b>	<b>84mmByWgt_SellBy_ET_SH_BCtop.blbl</b>
150	94mmByWgt_SellBy_ET_BCtop.blbl
151	94mmByCnt_SellBy_ET_BCtop.blbl
152	94mmStdPack_SellBy_ET_BCtop.blbl
153	94mmByWgt_SellBy_ET_SH_BCtop.blbl
<b>160</b>	<b>107mmByWgt_SellBy_ET_BCtop.blbl</b>
<b>161</b>	<b>107mmByCnt_SellBy_ET_BCtop.blbl</b>
<b>162</b>	<b>107mmStdPack_SellBy_ET_BCtop.blbl</b>
<b>163</b>	<b>107mmByWgt_SellBy_ET_SH_BCtop.blbl</b>
170	119mmByWgt_SellBy_ET_BCtop.blbl
171	119mmByCnt_SellBy_ET_BCtop.blbl
172	119mmStdPack_SellBy_ET_BCtop.blbl
173	119mmByWgt_SellBy_ET_SH_BCtop.blbl
<b>180</b>	<b>130mmByWgt_SellBy_ET_BCtop.blbl</b>
<b>182</b>	<b>130mmByCnt_SellBy_ET_BCtop.blbl</b>
<b>183</b>	<b>130mmStdPack_SellBy_ET_BCtop.blbl</b>
<b>184</b>	<b>130mmByWgt_SellBy_ET_SH_BCtop.blbl</b>

## Label Requirements

These thermal labels requirements apply to the BPro® printers. This section includes dimensional requirements, for labels and label rolls, as well as general requirements for label paper, thermal coatings, preprinting inks and adhesives.

Use of label materials and designs which meet with these requirements is necessary to ensure operation of the printers in compliance with their respective functional specifications and satisfactory performance of the label in the end use environment. Labels which do not comply with all of the requirements may function with limitations, but would need to be tested by the customer to insure adequate performance in their application. Customer specified (COD) software is not covered under this specification.

## Label Paper

DESCRIPTION, PRICE LABEL: Premium white color, black imaging, with protective coating

WEIGHT: 72 ± 7 grams/square meter

THICKNESS: 82 ± 14 μ meter (0.0032 inch)

### ACTIVATION TEMPERATURE

- STANDARD: Initial 74°C (165°F); Optimum 83°C (181°F)
- HIGH SPEED: Initial 66°C (151°F); Optimum 77°C (170°F) – for highest speed printing
- HOT BOX: Initial 83°C (181°F); Optimum 91°C (195°F) - for use on food items which are kept warm (Slow print speed setup required)

SURFACE SMOOTHNESS: The surface of the finished coated paper must be smooth to prevent premature print head failure. Smoothness must be 40 Sheffield units or smoother.

ION CONTENT: Ions such as sodium (Na) and chlorine (Cl) can cause premature failure of the glass overcoat of a thermal print head. Paper manufactured specifically for thermal printing with low ion content must be used.

STORAGE LIFE: 18 months minimum when stored at less than 85% relative humidity and less than 35°C (95°F)

### ADHESIVE

Permanent pressure sensitive – Nominal thickness 10 μ meter (0.0004 inch)

Label must adhere to product with a surface temperature of -15° C (5° F) minimum.

Bond strength must remain permanent over a temperature range of 2°C to 35°C (35°F to 95° F)

### RELEASE LINER

DESCRIPTION: White semi-bleached supercalendered Kraft paper with silicone release coating.

BASIS WEIGHT: 68 ± 3 gram/square meter

THICKNESS: 67 ± 7 μ METER (0.0026 INCH)

### TOTAL THICKNESS LABEL + ADHESIVE + LINER

Total Thickness Label + Adhesive + Liner: 159 ± 17 μ METER (0.0056 to 0.0069 inch)



**LIGHT TRANSMISSION FOR GAP SENSOR OPERATION:**

Light transmission at 800 to 900 NM wave length through the liner only must be at least 3 times the transmission through the liner and label together. This means that the transmission optical density of the liner must be at least 0.48 less than the that of the liner and label together.

Light transmission at 800 to 900 NM wave length through the liner and label together must be at least 2% of incident light. This corresponds to an optical density of 1.7.

Also see OPTICAL DENSITY DEFINITION further in this chapter.

---

**Label Stripping**

Labels must strip from the liner over a temperature range of 2°C (26°F) at 50% RH to 43°C (110°F) at 85% RH.

---

**Finished Label Roll  
Requirements**

**CORE AND METHOD OF LABEL ATTACHMENT**

The label stock must **not** be permanently attached to the cardboard core. The liner must separate cleanly from the core with 1.0 pound pull tangent to the core as shown in the figure below. No core material, tape, or adhesive is to remain on the label or liner after separation. Material, especially hot melt adhesive, remaining on the label will damage the print head.

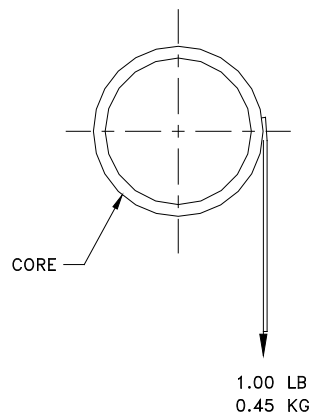

**DIE CUTTING**

Die cutting of the labels must not perforate the release liner.

**SLITTING**

The release liner must be slit cleanly and be made free of edge slivers and dust by vacuuming or some equally effective process.

### WINDING

The labels must be wound face out as shown in the figure to the right. The finished roll must be made free of paper dust and loose particles by vacuuming or some equally effective process.

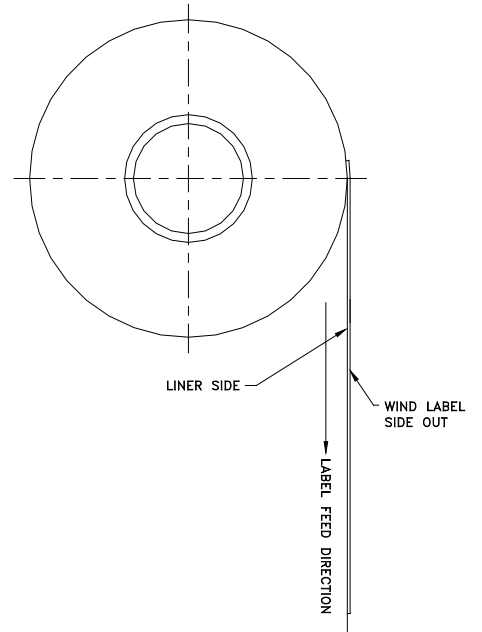

### LABEL CURL

Stripped labels must not curl more than 0.20 inch as specified in the figure below.

**Note:** Dimensions in inches with millimeters shown in ( ).

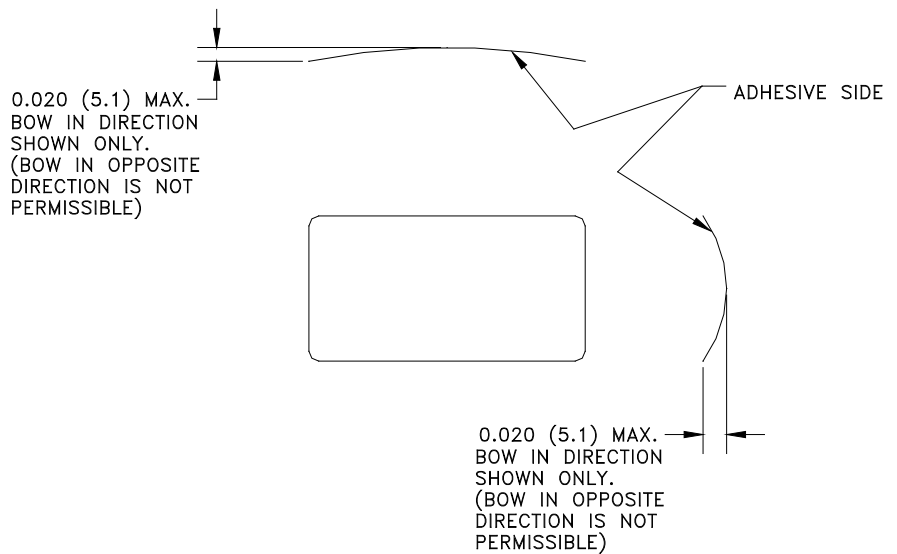

**SPLICING**

Each roll may contain one splice on non-label side of liner using 0.002 inch maximum thickness tape as shown in the next figure.

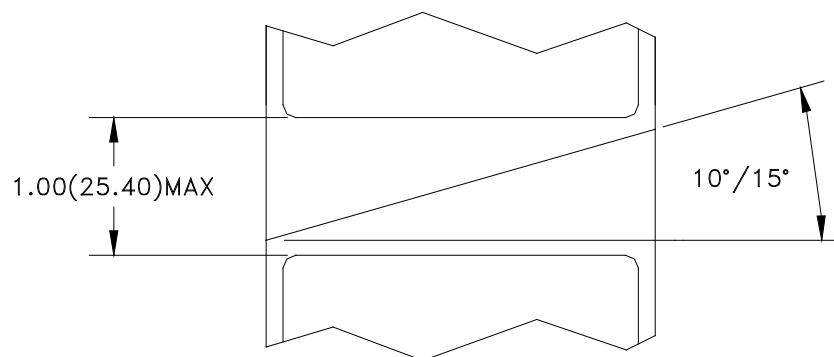

# Finished Label and Roll Dimensional Requirements

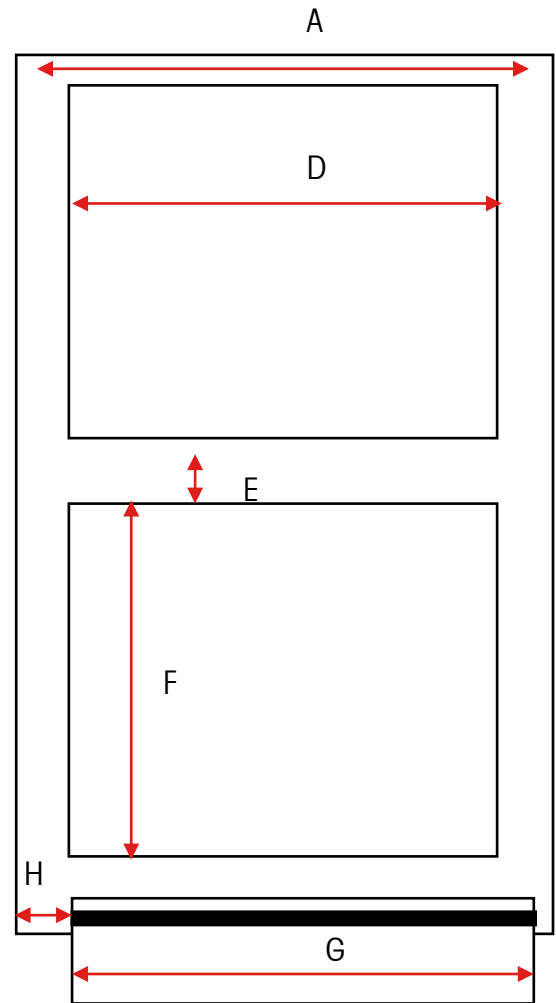
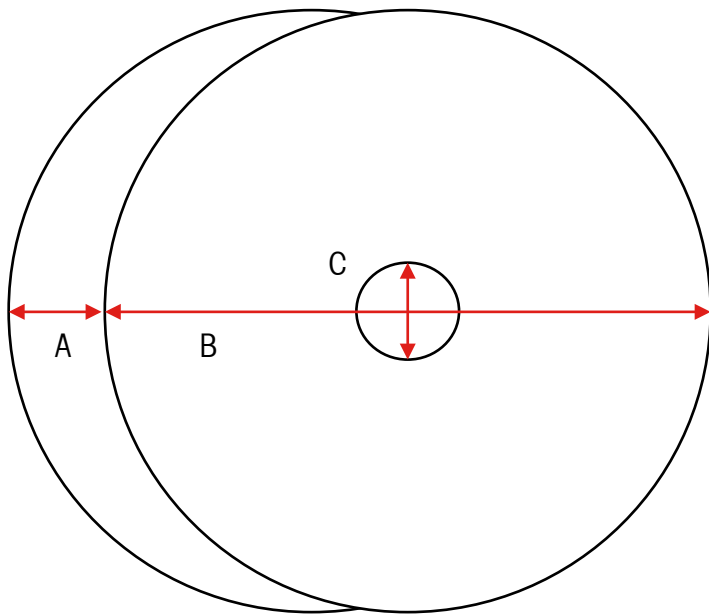

Item	Description	Range	BPro	
			2"	
			Inches	MM
A	Liner Width	Max	3.268	83
		Min	1.575	40
B	Roll Diameter	Max	4.7	120
C	Core Inside Diameter	Min	1.575	40
D	Label Width	Max	3.150	80
		Min	1.575	40
E	Gap Width	Max	0.236	15
		Min	0.078	2
F	Label Length	Max	7.8	200
		Min	0.9	23
G	Effective Print Width	Max	2.10	54
H	Left side Offset	Min	0.157	4

### Typical Dimensions – 2" Label Roll

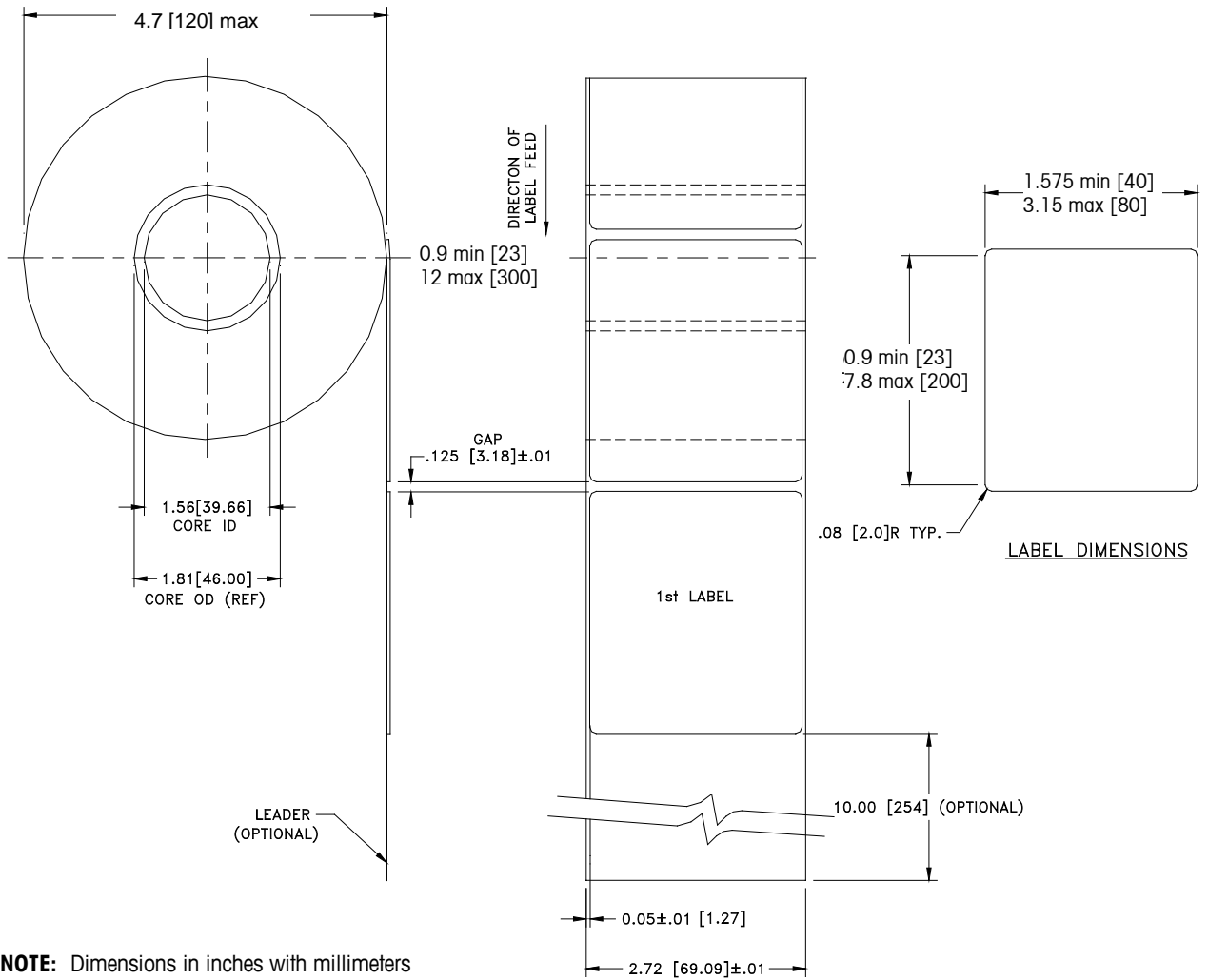

**NOTE:** Dimensions in inches with millimeters shown in [ ].

**bPro only prints 54mm wide**

FINISHED ROLL AND LABEL DETAIL – PRICE LABEL

## Preprinted Labels

To ensure trouble free operation of the printer gap sensor, and to achieve normal print head life, no pre printing should be placed on the label in the gap sensor path or in areas which will be printed by the scale printer (see following figure). However, since preprinting is commonly used by many customers the following guidelines must be followed.

1. Inks used for preprinting must be specially formulated for use in thermal printers. If proper inks are not used they can adhere to the print head. This ink build up on the print head will interfere with heat transfer from the print head to the paper and cause printing elements to burn out. Another problem with inks not formulated for thermal printing is that they can contain chemicals which will cause the glass overcoat to chip off of the print head, causing failure to print in the chipped areas.

2. If black ink is used in preprinting in the gap sensor path shown in the figure below, a dense black stripe will have to be printed on the back of the liner, as shown in the Black Stripe figure, to prevent the gap sensor from being affected by the black preprinting. (Colors other than black might also be a problem and should be tested by the customer) The black stripe must have gaps which correspond to the label gaps. The black stripe on the liner must have a minimum transmission optical density of 2.3 and must be uniform. In addition, the gap sensor circuit will need to be adjusted for operation with the black stripe as explained in the product service manual. This adjustment will need to be checked any time label paper is changed, for example when labels are procured from a new supplier.

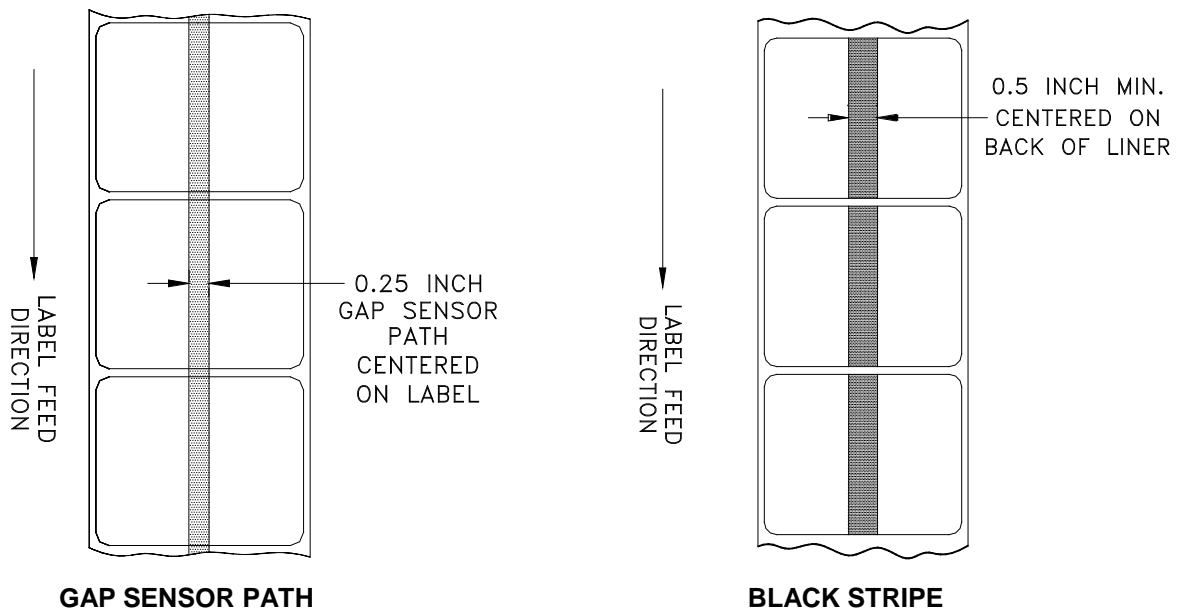

3. If an optical density of at least 2.3 cannot be achieved in the black stripe on the back of the liner. The sensor path in the center of the label must be free of black preprinting.

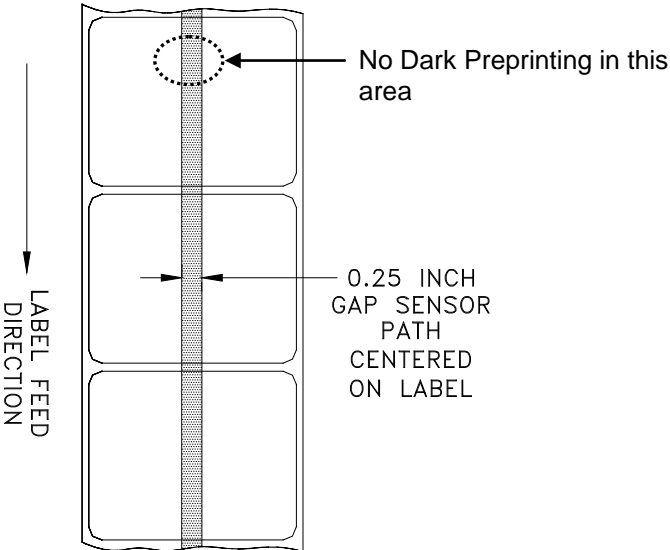

## Special Shaped Labels

Labels with shapes other than rectangular will cause gap detection errors if the gap dimension (in the gap sensor path) is outside the limits given in this document, or if the edge of the label shape crosses into and out of the sensor path as shown below. For these cases the black stripe will have to be printed on the back of the liner as shown previously. Tests will be needed to determine if the stripe will be adequate or if additional liner width will be required. The safe approach is to use the black stripe configuration shown previously on all odd shaped labels.

EXAMPLES OF ODD SHAPED LABELS WHICH WILL CAUSE GAP SENSOR PROBLEMS AND WILL NEED BLACK STRIPE

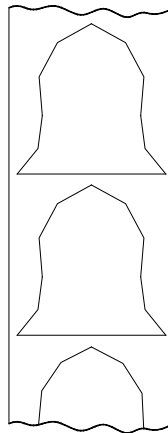

Fish

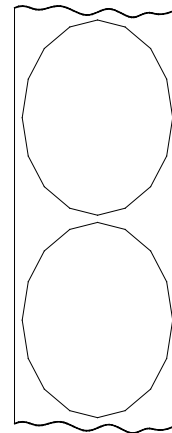

Oval or Round

## Definition of Transmission Optical Density

Transmission optical density is defined as:

$$\text{Optical Density} = \log_{10} (\text{incident light} / \text{transmitted light}) = \log_{10} (100 / \% \text{ light transmission})$$

Transmission optical density can be measured with a transmission densitometer that meets ANSI standards. Examples are the Macbeth model TD903 and TD932.

$$\text{Optical density for 100\% light transmission} = \log_{10} (100/100) = \log_{10} (1) = 0$$

$$\text{Optical density for 0.1\% light transmission} = \log_{10} (100/0.1) = \log_{10} (1000) = 3$$



## Label and Liner Optical Density

If liner paper transmits 2% of the light which is incident on it, the optical density is  $\log_{10} (100/2) = 1.7$

If the light transmitted through the liner is 3 times the light transmitted through the liner and label, the relative optical densities are:

$$\begin{aligned}\text{Optical Density of Liner + Label} &= \log_{10} (100 / X) \\ \text{Optical Density of Liner Only} &= \log_{10} (100 / 3X) \\ &= \log_{10} (0.3333X) \\ &= \log_{10} 0.3333 + \log_{10} (X) \\ &= \log_{10}(X) - 0.48\end{aligned}$$

Therefore, if the liner must transmit 3 times the light that the liner and label transmits, the transmission optical density of the liner must be 0.48 less than the transmission optical density of the liner and label.

## Black Stripe Optical Density

If only 0.5 % of incident light is transmitted through the black stripe, the optical density is:

$$\log_{10} (100 / 0.5) = \log_{10} (200) = 2.3$$

The purpose of specifying a transmission optical density of at least 2.3 for the printed black stripe on the back of the label is to minimize any variation in light transmission as a result of black pre-printing on the front of the label. This variation due to black preprinting can cause the gap sensor to give gap detection errors.



# METTLER TOLEDO

For your notes

# 5

## Maintenance

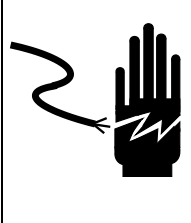
### Unit Cleaning

	<p style="text-align: center;"> <b>WARNING</b></p> <p>Disconnect all power to this unit before installing, servicing, cleaning, or removing the fuse. Failure to do so could result in bodily harm and/or property damage. Do not spray or wash down. Hazard of electrical shock or burn.</p>
---	---

- Disconnect Power
- Open the printer door by pressing down on the release tab.
- Do not use solvents or commercial cleaners on the unit. They may harm the surfaces or damage the Keypad.
- **Do not spray directly on or at the unit!**

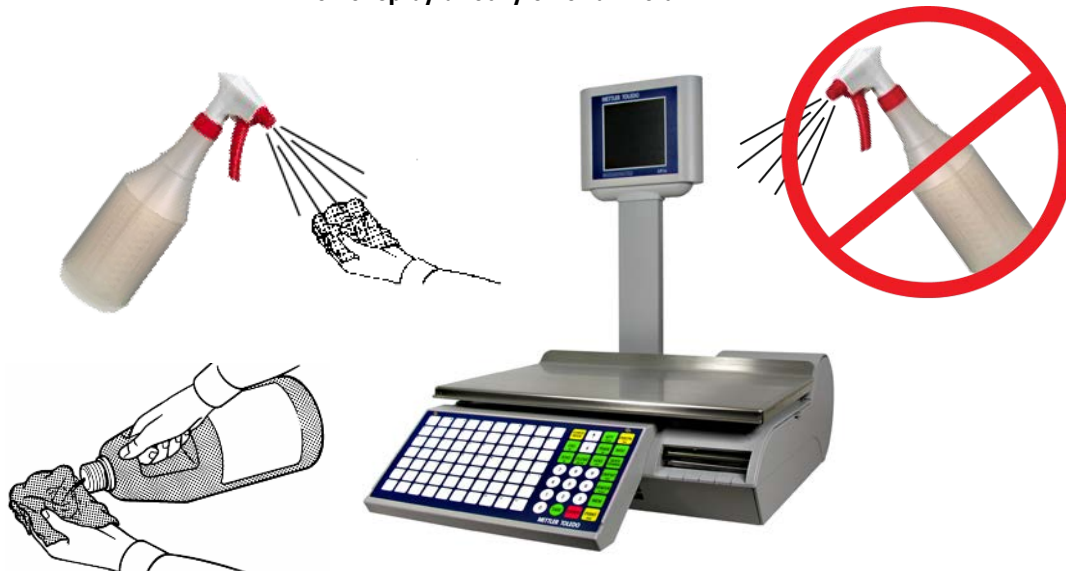

- Keypad and Customer Displays - **Only use a soft clean cloth** dampened with mild detergent and water to clean the Keypads and Customer display screen. Do not scrape with sharp objects.
- Covers and Platter – Clean using a soft clean cloth dampened with a mild cleaner or detergent and water.

## Printer Cleaning

Clean the printhead anytime you notice the print quality has degraded.

Slide the printer out, lift the printhead, and clean the printhead where it contacts the labels on the bottom using the cleaning pen or alcohol and a cotton swab to remove any label debris or glue.



### WARNING

**Do not use any metal or sharp object to scrape the printhead. This may cause serious damage.**

Press the latch to release and raise the printhead



Use the Cleaning Pen to clean any glue or debris from the black stripe area of the printhead. A cotton swab and alcohol may also be used in place of the cleaning pen.

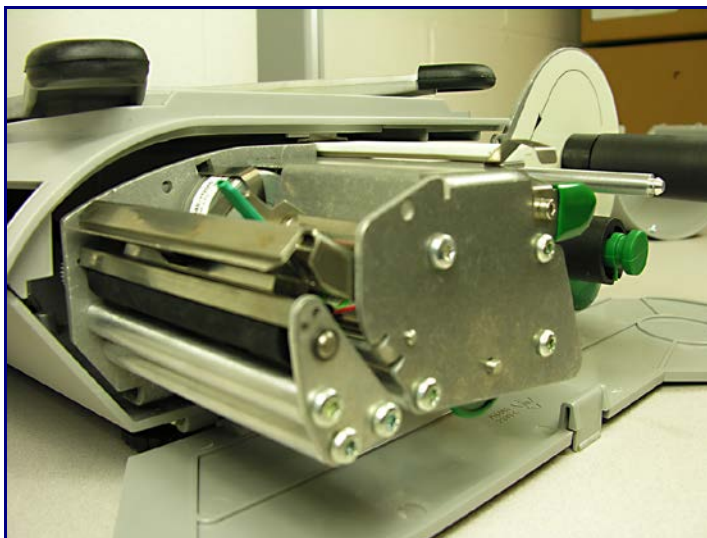

When doing regular maintenance, or when changing a label roll, check for any buildup on the Printer Roller (located under the tear strip).

When the printer is pulled out and before the new label roll is installed, rotate the labels. And then use the Cleaning Pen to get rid of excess buildup.

If dirt and dust have built up on the rubber portion of the Printer Roller, it too can be cleaned with alcohol and a cotton swab.

Again, use the Stage Label button to rotate the Roller and wipe it with an alcohol-moistened cotton swab. Rotate the Roller again and repeat the above procedure until the Roller is clean.

	 <b>WARNING</b>
	<b>FOR SAFETY: Do NOT touch Rollers with your fingers while the Rollers are in motion.</b>

# METTLER TOLEDO

For your notes

# 6

## Appendix

### Define barcode Digits

#### Barcode Identification Symbols

A = Item Number	4 – 12 figures
B = Total Price	4/5/6 figures
C = Check Digit	1 figure
D = Date	2/4/6 figures
N = Ticket Number	4 figures
P = PLU Code	4/5/6 figures
Q = Weight/Quantity	4/5 figures
W = Group Number	2 figures
U = Unite Price	
R = Department #	
O = Operator #	
M = Process Mode	
0 – 9 Figures	1 – 12 figures

#### Examples

0AAAAAAAAA	(UPC, Ten digit Item Number)
2AAAAACBBBB	(UPC, 5-D Item/Price Check Digit/4-D Price)
2AAAAA0BBBB	(UPC, 5-D Item/Zero Fixed/4-D Price)
2AAAAABBBBB	(UPC, 5-D Item/No Price Check/5-D Price)
2AAAAACQQQQ	(UPC, 5-D Item/Wgt Check Digit/4-D Wgt)
2AAAAAQQQQ	(UPC, 6-D Item/ No Price Check /4-D Wgt)
2AAAAQQQQQ	(UPC, 5-D Item/No Price Check/5-D Wgt)
21AAAAABBBBB	(EAN, 5-D Item/5-D Price)
21AAAAABBBBB	(EAN, 4-D Item/6-D Price)
21AAAAACBBBB	(EAN, 5-D Item/Price Check Digit/4-D Price)
21AAAAACBBBB	(EAN, 4-D Item/Price Check Digit/5-D Wgt)
21AAAAQQQQQ	(EAN, 5-D item/5-D WGT)
21AAAAACQQQQ	(EAN, 4-D Item/Wgt Check Digit/5-D Wgt)

# METTLER TOLEDO

For your notes







## METTLER TOLEDO Service



### **Quality Management System certification.**

Development, production, and auditing in accordance with ISO9001. Environmental management system in accordance with ISO14001.

### **Worldwide service.**

Our dense service network, among the best in the world, ensures the maximum availability and lifespan of your product.

### **Conformité Européene.**

This label is your guarantee that our products conform to the latest guidelines.

### **On the Internet.**

You can find important information about our products and services, as well as our company, quickly and easily at <http://www.mt.com/support>

## **METTLER TOLEDO**

1900 Polaris Parkway  
Columbus, Ohio 43240  
[www.mt.com](http://www.mt.com)

**METTLER TOLEDO®** and bPro® are registered trademarks of Mettler-Toledo, LLC  
©2015 Mettler-Toledo, LLC  
Printed in USA



64067202